

scale on bar
5.0.5673.010
5.0.5673.030
5.0.5673.050
takes all 3 pcs to
make one scale

Continuous feeder

B26E / B30E

SPARE PARTS LIST

These spare parts catalogues show you all important parts of the machine, delivery and feeder. The numeration of the individual parts correspond to our fabrication numbers. When ordering parts please always indicate the number, this enables us to handle your order faultless and without any delay.

It is also very important to indicate the type and serial number of the machine for which the spare parts are required.

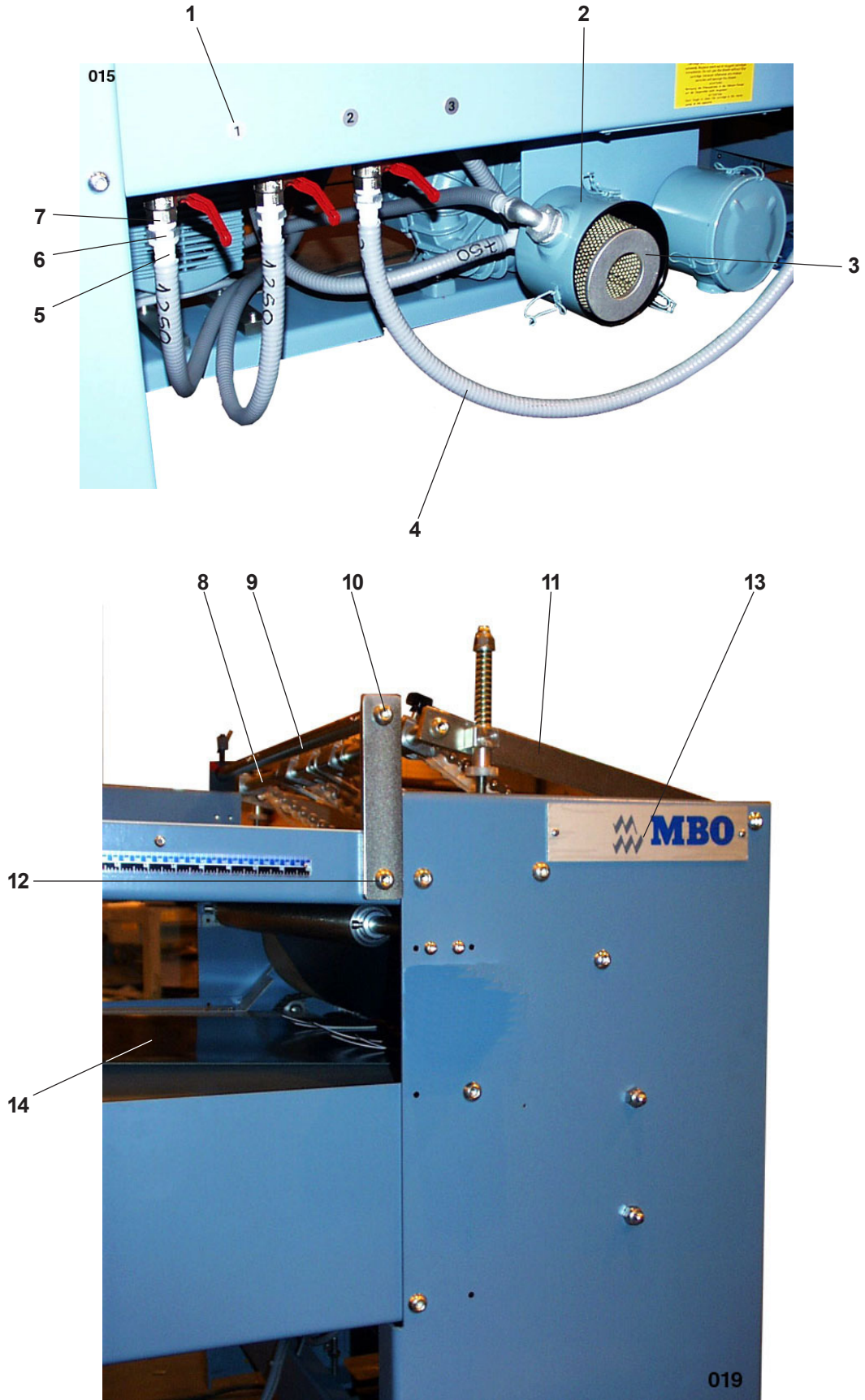

01	lable		No. 1	5.0.5471.051	
	lable		No. 2	5.0.5471.052	
	lable		No. 3	5.0.5471.053	
02	Airfilter unit		0099990		(F110)
03	Airfilter		0100013		(C1337)
04	Tube		00105029		(20 EVK 16)
05	Hose coupling		00084939		(R1/2"X3/4" Huenersdorff 5414)
06	Coupling		00084913		(Red. Nippel N4 R3/4" - R 1/2")
07	Airchoke		00085274		(IG 3/4" - AG 3/4" Typ 33)
08	Bar	B26E	01.3221.18		
		B30E	01.3221.19		
09	Bar with scale	B26E	01.3300.34		
		B30E	01.3300.35		
10	Screw		0096123.5		(M12x20 ULS)
11	Lever		5.0.3341.020		
12	Screw		0096131.5		(M12x25 ULS)
13	Schild		17.5171.01		
14	Transport tape		0107064		(550x4660)

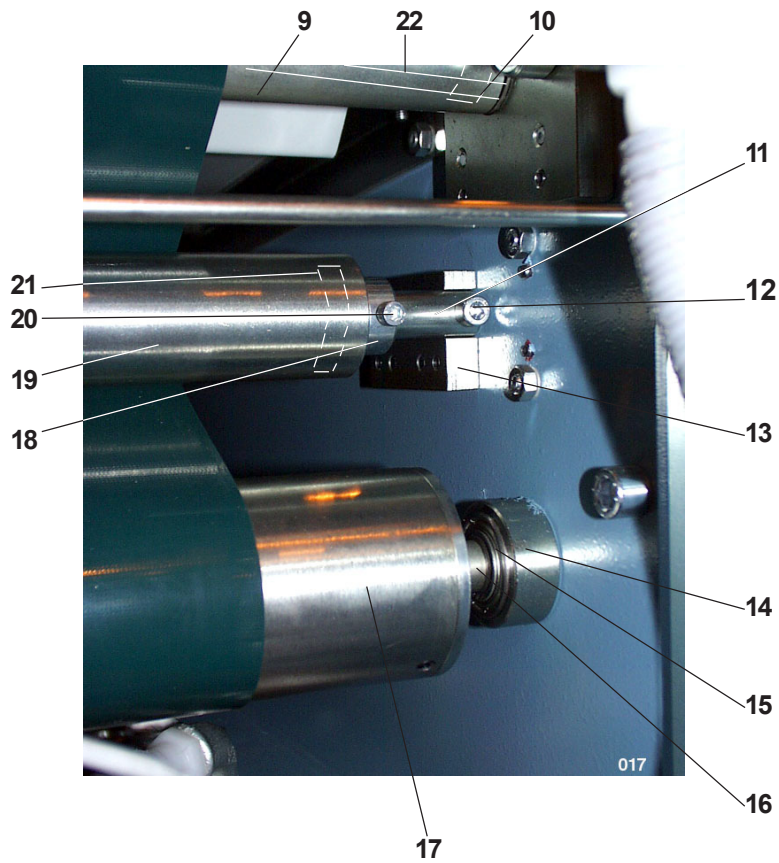
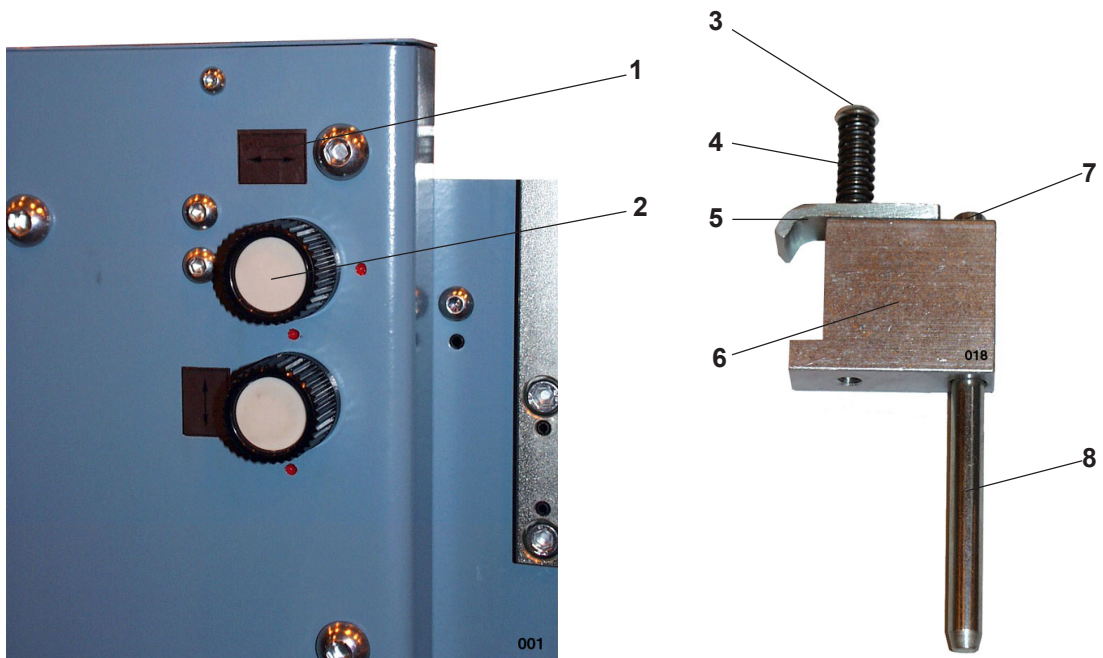

01	Lable		1.0.3571.010	
02	Knob		00100511	(37 x 6 GN 526)
03	Screw		0096077.5	(M8x45 ULS)
04	Spring		00102895	(D234-A)
05	Holder		4.0.3644.070	
06	Adjustment piece		4.0.3644.060	
07	Circlip		0094201.5	(8 DIN 6799)
08	Pin		5.0.3425.010	
09	Tape roller	B26E	01.3324.00	
		B30E	01.3324.01	
10	Ball bearing		00109686	(6003 2Z)
11	Shaft	B26E	01.3221.02	
		B30E	01.3221.03	
12	Screw		0089096.5	(M 8x65 DIN 912)
13	Bearing part		1.0.3144.020	
14	Bearing part		30 320 010	
15	Ball bearing		00109728	(6004 2Z)
16	Shaft	B26E	01.3221.08	
		B30E	01.3221.09	
17	Tape roller	B26E	01.3200.31	
		B30E	01.3200.32	
18	Ring		0088344.5	(A20 DIN 705)
19	Tape roller		1.23.3224.010	
20	Screw		0088781.5	(M6x10 DIN 912)
21	Collar / Ball bearing		07.3226.00/0109896	(2x 61804-2RS)
22	Bolt	B26E	01.3221.02	
		B30E	01.3221.01	

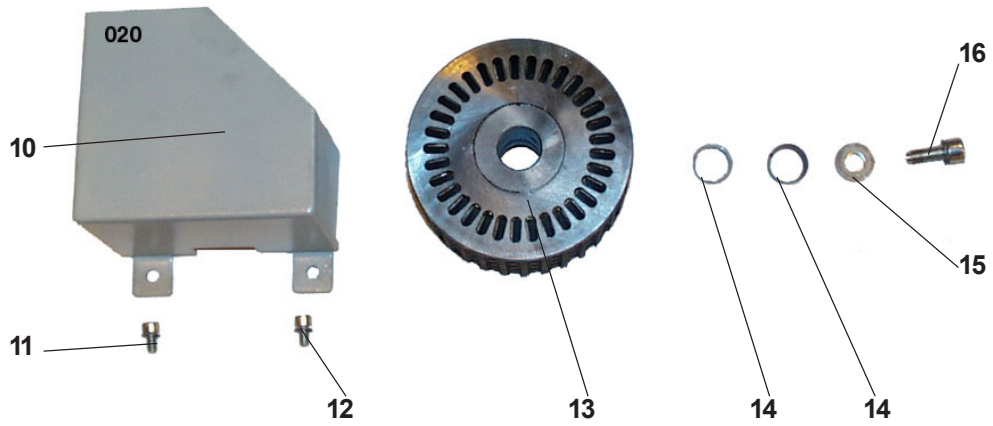
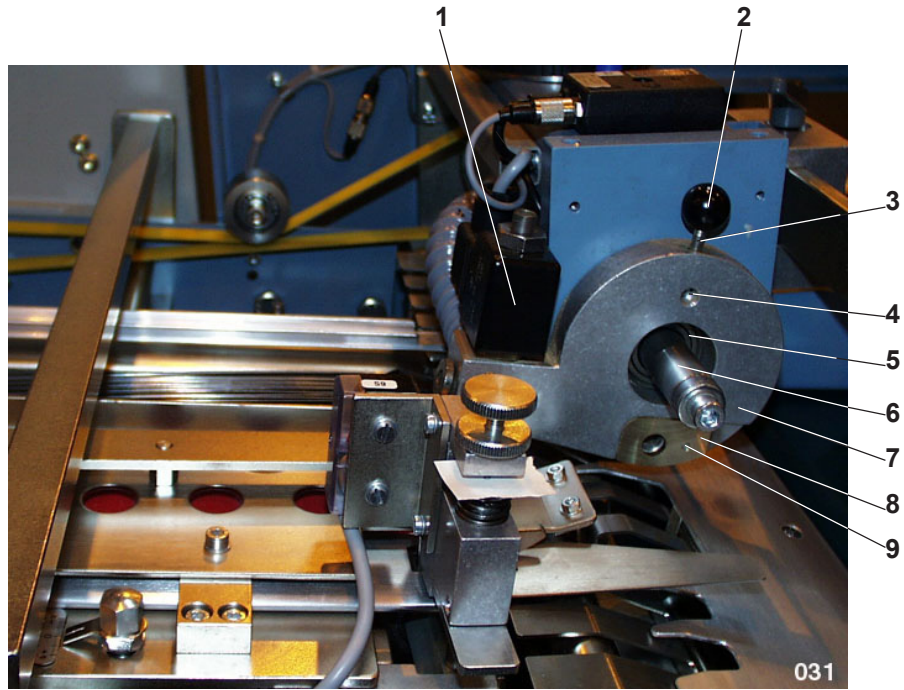

Accordion tape register table

01	Solenoid valve	00129817	(MV 330-0302301304)
02	Knob	00086504	(C20xM5 DIN 319)
03	Screw	0090274.5	(M5x25 DIN 933)
04	Screw	0089615.5	(M6x10 DIN 913)
05	Ball bearing	00109728	(6004-2Z)
06	Shaft	B26E 01.2221.00	
		B30E 01.2221.01	
07	Valve plate	1.0.2215.320	
08	Valve bush	1.0.2244.020	
09	Screw	0095257.5	(M4x10 DIN 7991)
10	Guard	1.0.2262.350	
11	Screw	0088799.5	(M6x12 DIN 912)
12	Washer	0086116.5	(6.4 DIN 125)
13	Suction wheel	01.2200.002	
14	Set ring spring	00101600	(RFN 8006)
15	Washer	0095679.5	(8.4 DIN 9021)
16	Screw	0088997.5	(M8x20 DIN 912)

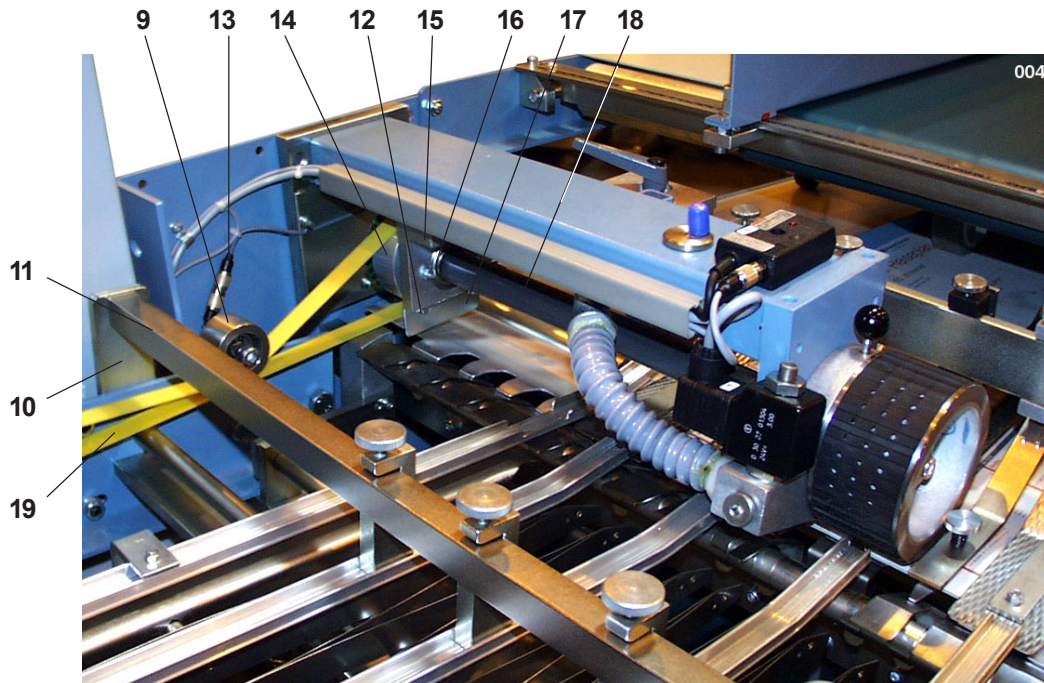
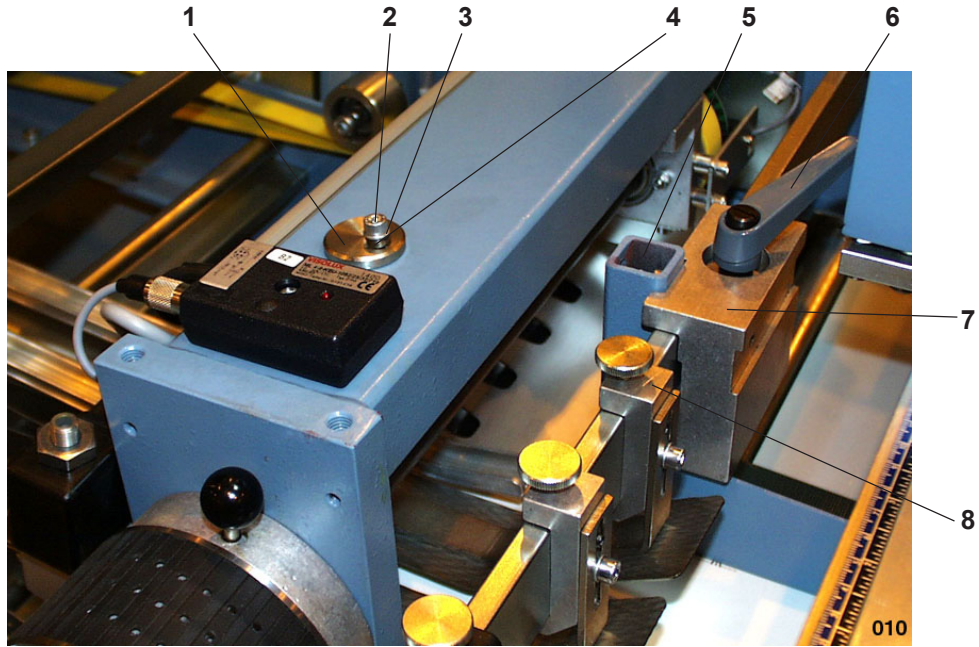

01	Washer	1.0.2228.310	
02	Screw	0088716.5	(M 5x30 DIN 912)
03	Washer	0086116.5	(6.4 DIN 125)
04	Spring	20 480 130	
05	Sheet stop	01.3464.00	
06	Handle	00100586	(M8x20 GN500)
07	Adjustment part	1.0.2444.320	
08	Smoother cpl.	15.3400.53	
09	Tape roller	70 230 042	
	Ball bearing	00109245	(6001-2Z)
10	Holder	1.0.4143.320	
11	Bar	01.4142.03	
12	Screw	0088641.5	(M5x10 DIN 912)
13	Initiator (Cable)	00131417	(GT 3.5)
14	Pulley	1.0.2232.021	
15	Bearing block	1.0.2244.311	
16	Ball bearing	00109728	(6004-2Z)
17	Guard	1.0.2262.310	
18	Tupe guard	01.2226.01	
19	Tape	00105908	(20x2300 PU11)

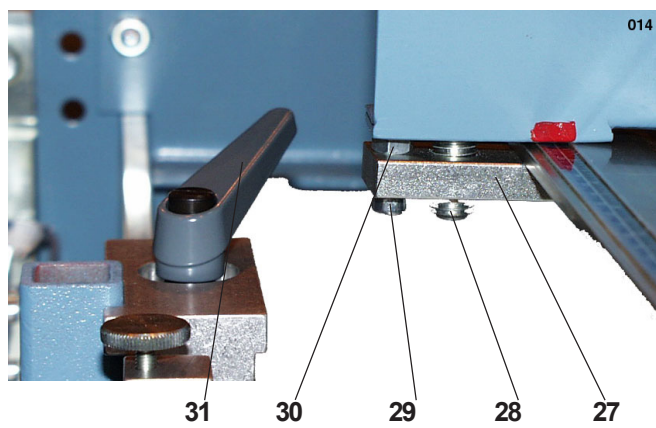
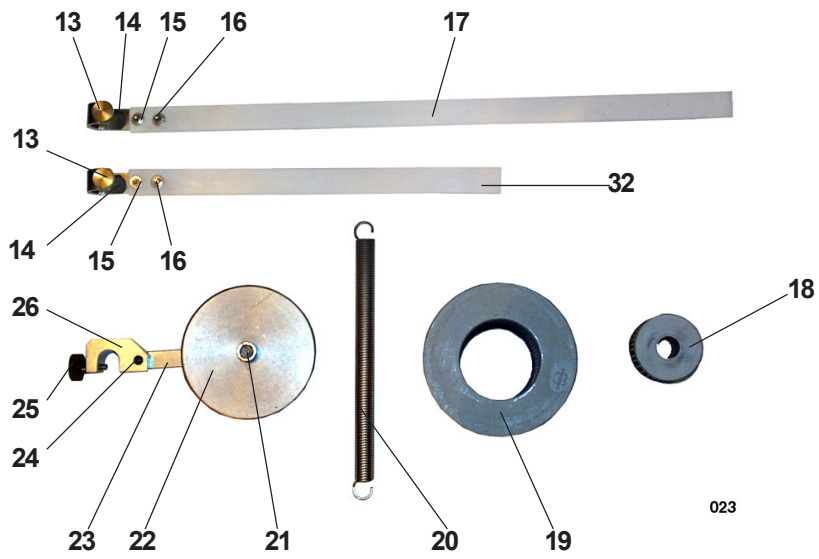
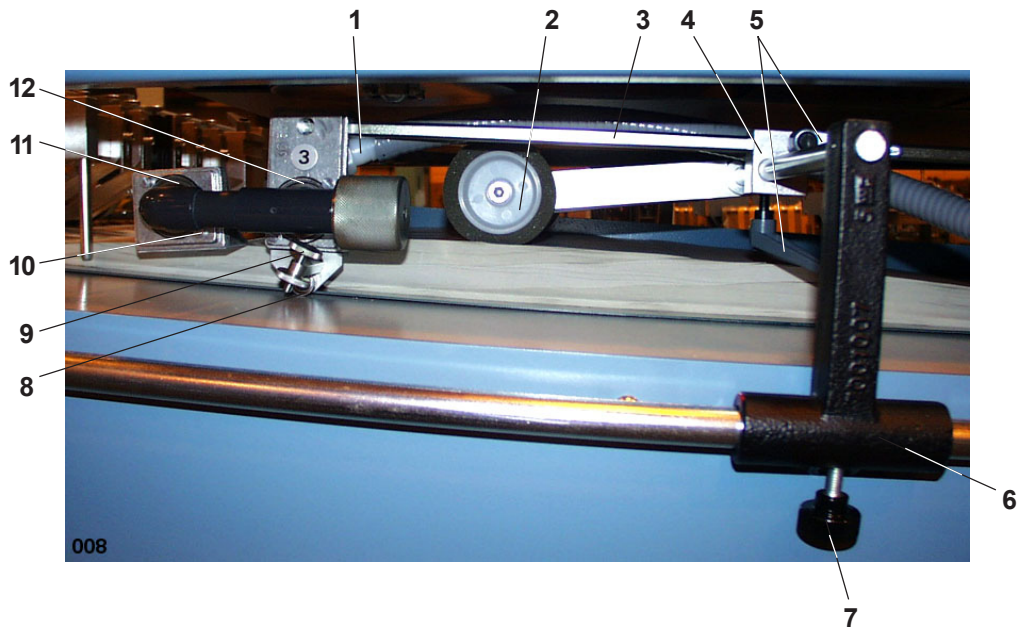

01	Concetion	00084939	(R1/2"X3/4" Huenersdorff 5414)
02	Roller	01.3200.60	
03	Bar	5.0.3621.010	
04	Holder	5.0.3644.010	
05	Handle	00100586	(M8x20 GN100)
06	Holder	1.0.3212.011	
07	Knurled screw	00095860	(M8x25 GN 421)
08	Ball bearing	00109561	(626-2Z DIN 625)
09	Knurled nut	0087148.5	(M6 DIN 467)
10	Screw	0085910.5	(M5x8 DIN 84)
11	Ball bearing	00109736	(6005-2Z-C3)
12	Holder	5.0.3615.010	
13	Screw	0087825.5	(M5x10 DIN 653)
14	Holder	2.0.3364.040	
15	Disc	0095646.5	(B4,3 DIN 9021)
16	Nut	0090837.5	(M4 DIN 934)
17	smoother	01.3202.02	
	Screw	0087825.5	(M5x10 DIN 653)
18	Airfilter	0100005.1	(C64/3)
19	Airfilter	0100013	(C1337)
20	Spring	01.3282.00	
21	Screw	0089300.5	(M12x40 DIN 912)
22	Roller	08.3211.00	
23	Holder	08.3244.08	
24	Pin	00093971	(6x32 DIN 6325)
25	Knurled screw	00095810	(M6x15 GN 421)
26	Holder	08.3244.07	
27	Holding part	1.0.3343.310	1.0.3443.310
28	Threadede bolt	80 430 030	
29	Screw	0088997.5	(M8x20 DIN 912)
30	Nut	0090878.5	(M8 DIN 934)
31	Handle	00100586	(M8x20 GN100)
32	Smoother	01.3202.01	
13-16+32	Smoother cpl.	01.3200.19	
13-17	Smoother cpl.	01.3200.20	
21-26	Smoother cpl.	08.3200.15	

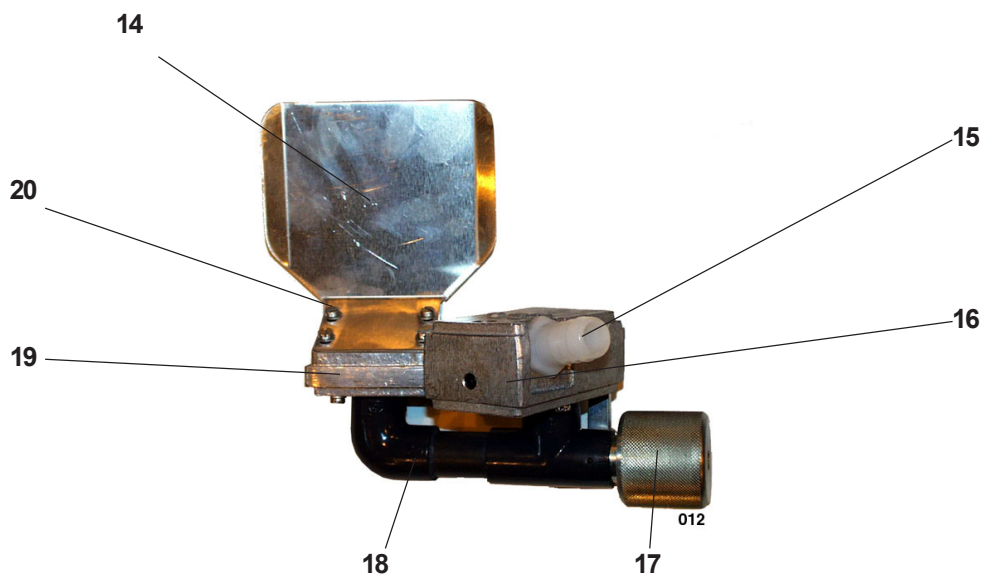
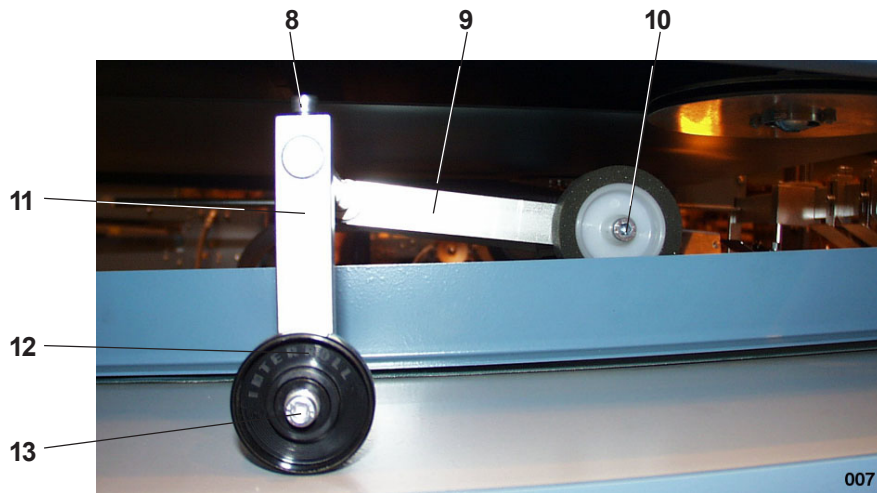
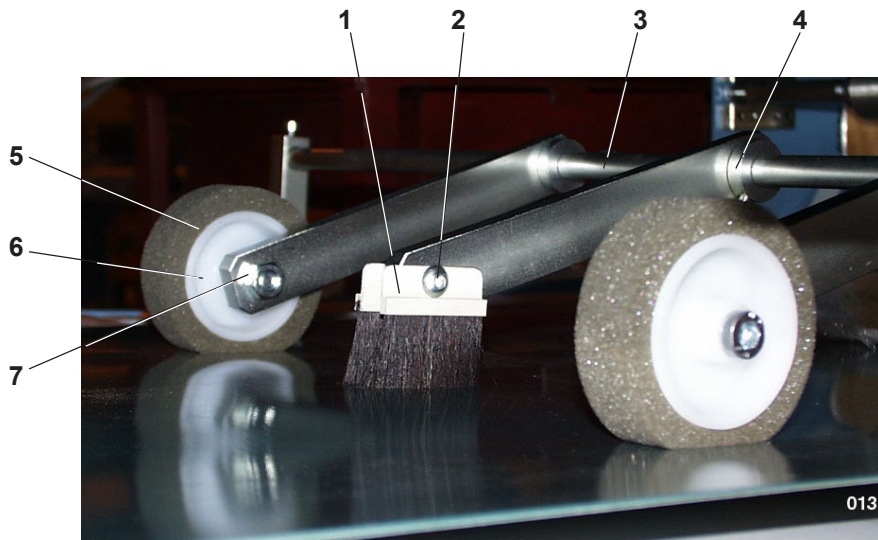

01	Brush		3.0.6943.010	
02	Screw		0096065.5	(M8x25 ULS)
03	Bar	B26E	01.3721.00	
		B30E	01.3721.01	
04	Ring		01.3228.00	
05	Ring		01.3239.20	
06	Roller		01.3232.20	
07	Nut		0090894.5	(M10 DIN 934)
08	Screw		0089037.5	(M8x35 DIN 912)
09	Lever		01.3244.02	
10	Screw		0089222.5	(M10x60 DIN 912)
11	Holder		1.0.3243.012	
12	Rolle		00109504	(D48mm)
13	Screw		0088864.5	(M6x35 DIN 912)
14	Blower		5.0.3661.020	
15	Tube part		00084939	(R1/2" x 3/4" Huenersdorff 5414)
16	Holder		5.0.3615.010	
17	Weight		5.0.3629.020	
18	Blower tube		5.0.3600.270	
19	Blower holder		5.0.3615.020	
20	Screw		0085910.5	(M5x8 DIN 84)
Pos. 14-20	Side blower cpl.		01.3600.02	

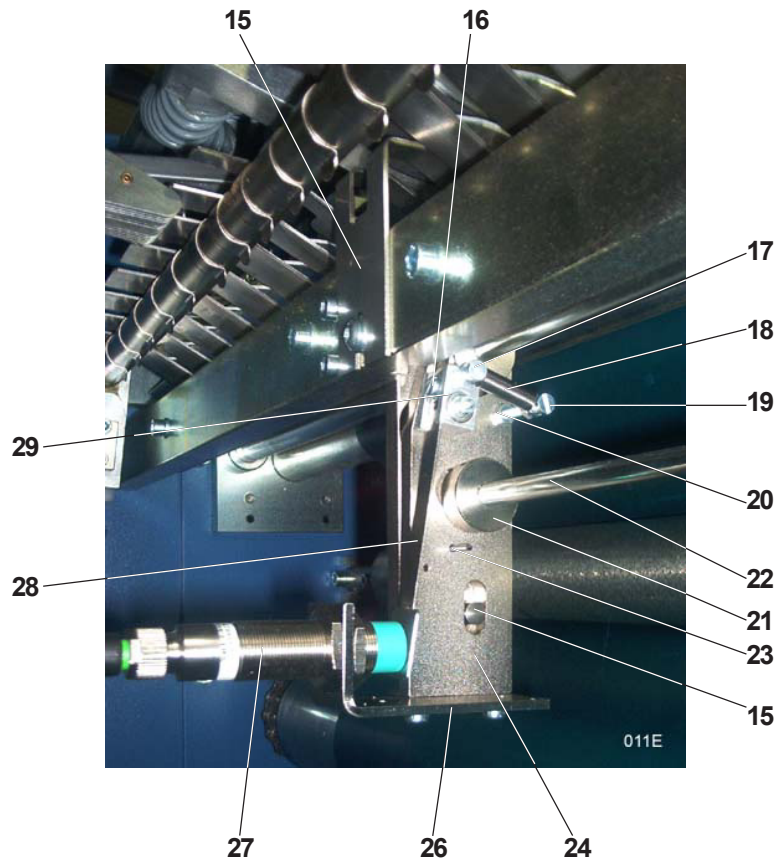
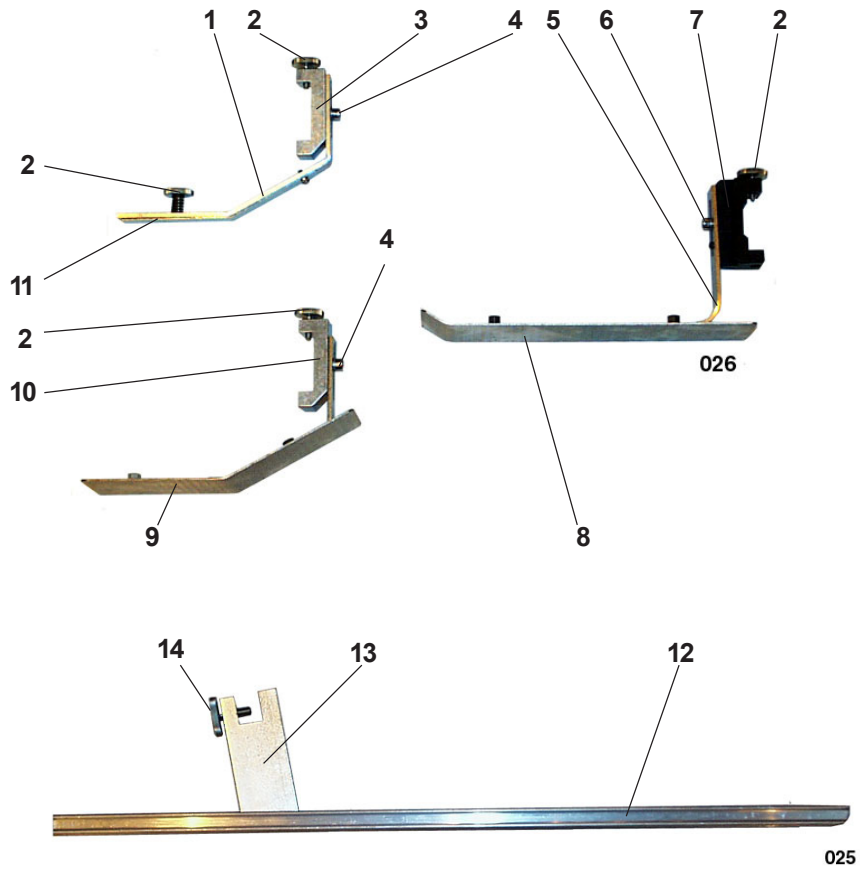

01	Holder		15.3485.51	
02	Knurled screw		0087858.5	(M5x16 DIN 653)
03	Holder		15.3444.51	
04	Screw		0088658.5	(M5x12 DIN 912)
05	Holder		35.2444.05	
06	Screw		0088658.5	(M5x12 DIN 912)
07	Holder		2.0.2414.010	
08	Smoother		35.2462.01	
09	Smoother		15.3485.53	
10	Holder		15.3444.51	
11	Smoother		15.3485.52	
12	Bar		1.0.3651.310	
13	Holder		1.0.3644.310	
14	Knurled screw		0087833.5	(M5x12 DIN 653)
15	Sheet stop		1.0.3562.020	
16	Screw		0085761.5	(M4x6 DIN 84)
17	Screw		0085829.5	(M4x16 DIN 84)
18	Spring		00102584	(Z-024A JI)
19	Screw		0085886.5	(M4x30 DIN 84)
20	Nut		0090857.5	(M4 DIN 934)
21	Excenter		1.0.3525.020	
22	Bar	B26E	01.3521.00	
		B30E	01.3521.01	
23	Pin		00093104	(2x20 DIN 1481)
24	Plate		17.3544.02	
25	Pin		00093955	(8M6x20 DIN 6325)
26	Holder		10.3562.02	
27	Inductive switch		0131507	(NT 2.8 0131425 E94)
28	Lever		10.3562.01	
29	Bearing block		17.3544.00	
1-4+11	Smoother cpl.		15.3400.52	
2+5-8	Smoother cpl.		1.0.2400.310	
2+4+9+10	Smoother cpl.		15.3400.53	
12-14	Smoother cpl.		01.3600.00 (6x)	

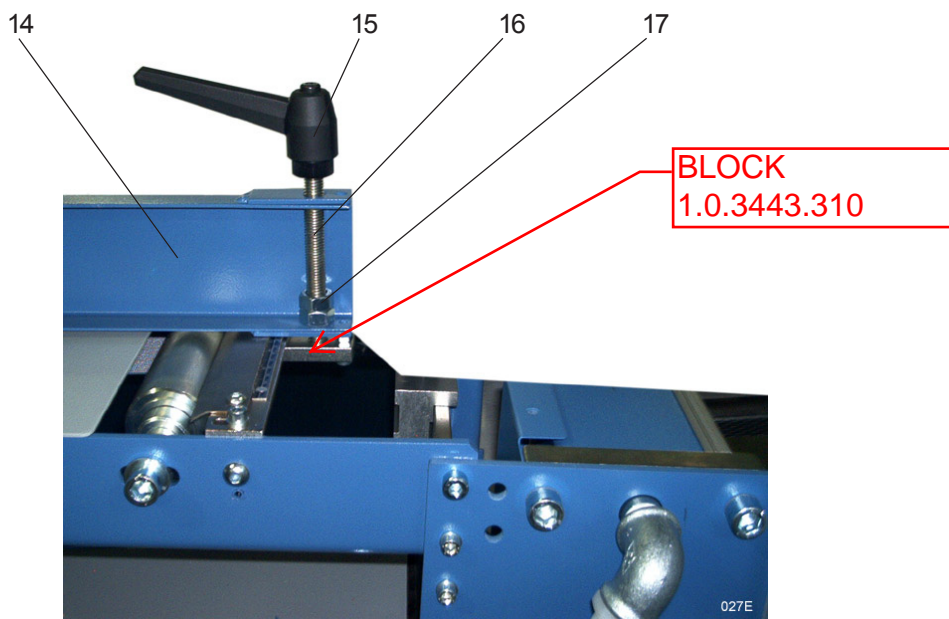
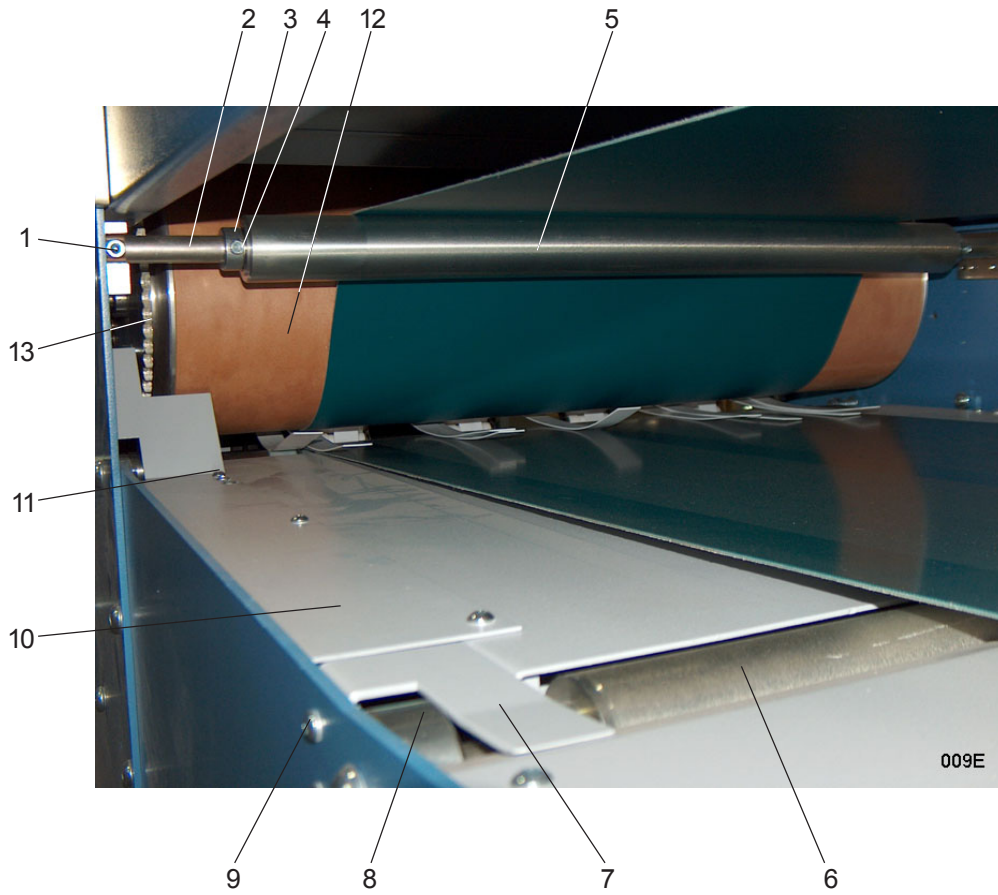

01	Screw		0088914.5	(M6x60 DIN 912)
02	Shaft	B26E	01.3321.05	
		B30E	01.3321.06	
03	Ring		0088344.5	(A 20 DIN 705)
04	Screw		0088781.5	(M6x10 DIN 912)
05	Tape roller		1.23.3224.010	
06	Tape roller	B26E	01.3224.03	
		B30E	01.3224.04	
07	Guard		01.3162.00	
08	Ball bearing		00109728	(6004 2Z)
09	Screw		0095992.5	(M6x16 ULS)
10	Guard		01.3261.00	
11	Screw		0095984.5	(M6x12 ULS)
12	Tape roller	B26E	1.7.3332.040	
		B30E	01.3332.00	
13	Chain wheel		11.3335.00	
14	Sheet stop		01.3464.02	
15	Handle		00100586	(M8x20 GN100)
16	Screw		80 430 030	
17	Nut		0090910.5	(M12 DIN 934)
11-13	Drumm cpl.	B26E	01.3300.30	
		B30E	01.3300.31	

GN500-100M12-SW

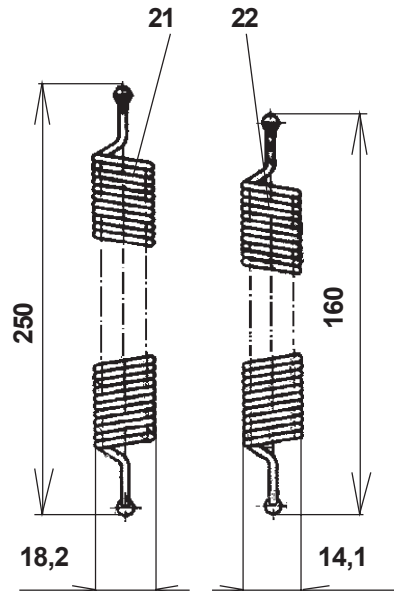
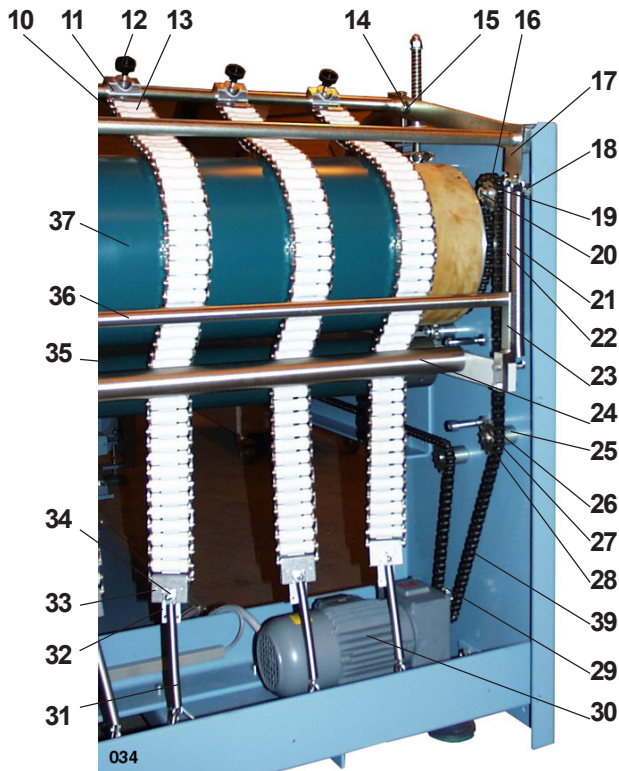
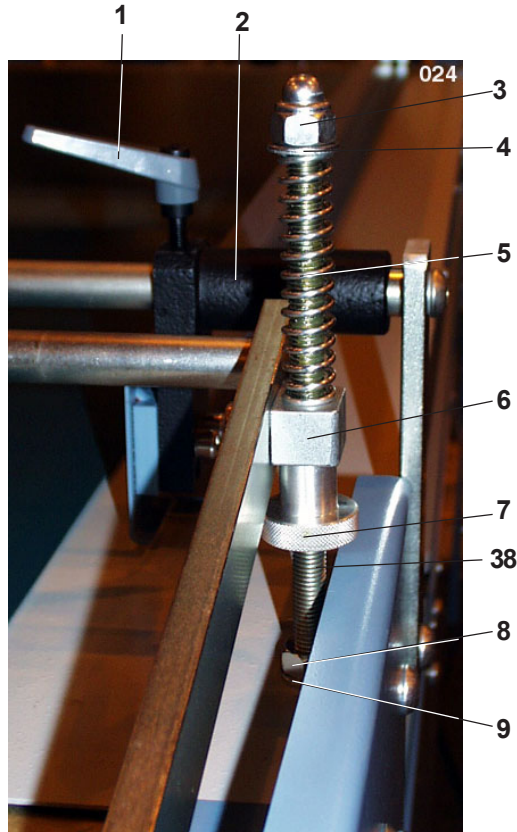

01	Handle		00100586	(M8x20 GN500)
02	Holder		1.0.3464.010	
03	Nut		0092171.5	(M12 DIN 986)
04	Washer		0086215.5	(13 DIN 125)
05	Compression spring		0103011	(D282)
06	Holder		5.0.3344.020	
07	Nut		5.0.3329.010	
08	Nut		0090910.5	(M12 DIN 934)
09	Washer		0086215.5	(13 DIN 125)
10	Chain link		08.3207.00	(Iwis no. 3 Steckglied)
11	Holder		08.3244.02	
12	Screw		00100586	(GN 100-18 M 8x20)
13	Roller		08.3526.00	
14	Clips		00087205	(A15x1 DIN 471)
15	Disc		00092312	(15x22x1.0 DIN 988)
16	Bolt		1.0.3325.310	
17	Holder		01.3244.06	
18	Lever		1.0.3343.360	
19	Sprocket	20 260 080 /	00111351	(20x26x20 DIN 1850)
20	Screw		0089318.5	(M12x45 DIN912)
21	Spring		01.3282.01	
22	Spring		01.3282.00	
23	Holder		01.3264.02	
24	Shaft		1.7.3332.030	
25	Bolt		01.3225.00	
26	Sprocket	20 260 080 /	00111351	(20x26x20 DIN 1850)
27	Clips		00087247	(20x1,2 DIN 471)
28	Disc		00092429	(20x28 DIN 988)
29	Sprocket		1.0.3135.310	
30	Motor		0103901	(DMK 632)
31	Spring		01.3282.00	
32	Tape		01.3200.17	
33	Holder		08.3244.04	
34	Screw		0095406.5	(M6x16 DIN 7991)
35	Tape roller cpl.	B26E	01.3200.11	
		B30E	01.3200.10	
36	Bar	B26E	1.7.3321.040	
		B30E	01.3321.07	
37	Transporttape		0107063	(550x4405 endlos PVC-hart)
38	Adjusting screw		5.0.3325.020	
39	Chain cpl.		01.3200.05	

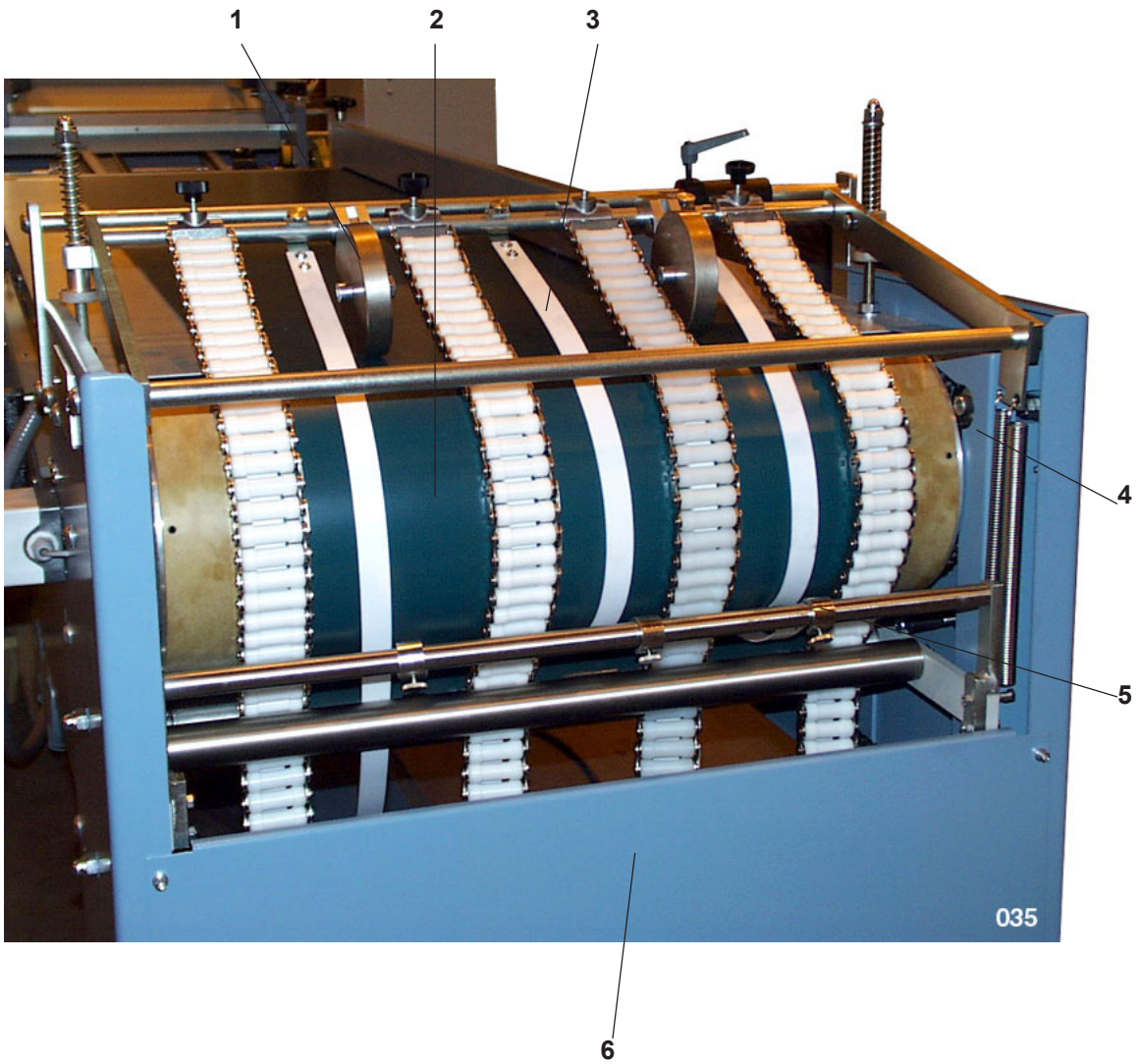

01	Roller cpl.		08.3200.15	
02	Tape		0107063	(550x4405 endlos PVC-hart)
03	Smoother		01.3200.20	
04	Guard		1.0.3161.320	
05	Smoother		01.3200.19	
06	Guard	B26E	01.3161.00	
	Guard	B30E	01.3161.01	

MBO Portugal



MBO Binder
Máquinas Gráficas, S.A.
Rua Joaquim Alves da Silva 240, 420 e 570
4455-473 Perafita

Tel: (+351) 22 - 9982200
Fax: (+351) 22 - 9982201

info@mbo-folder.com

MBO Deutschland



MBO Binder GmbH & CO. KG
Postfach 1169
D-71567 Oppenweiler

Tel: (+49)(0)7191-46 0
Fax: (+49)(0)7191-46 34

<http://www.mbo-folder.com>
info@mbo-folder.com



Parallel unit to 32 page unit

B26E / B30E

SPARE PARTS LIST

These spare parts catalogues show you all important parts of the machine, delivery and feeder. The numeration of the individual parts correspond to our fabrication numbers. When ordering parts please always indicate the number, this enables us to handle your order faultless and without any delay.

It is also very important to indicate the type and serial number of the machine for which the spare parts are required.

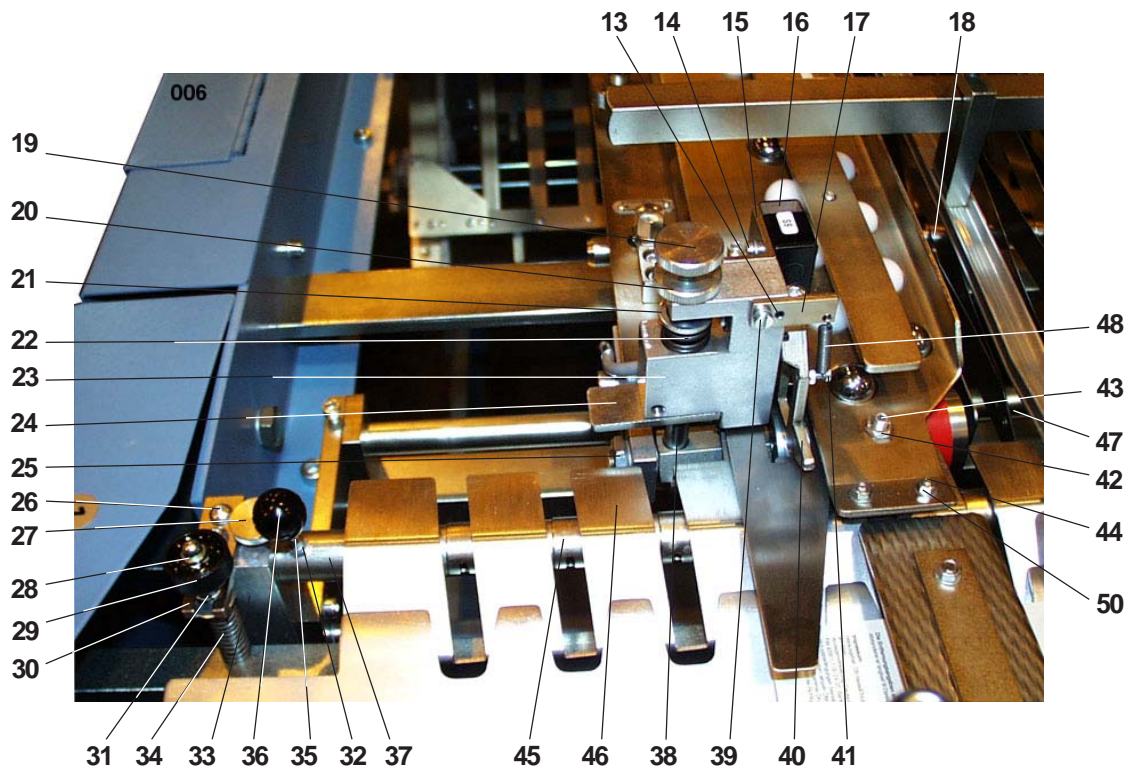
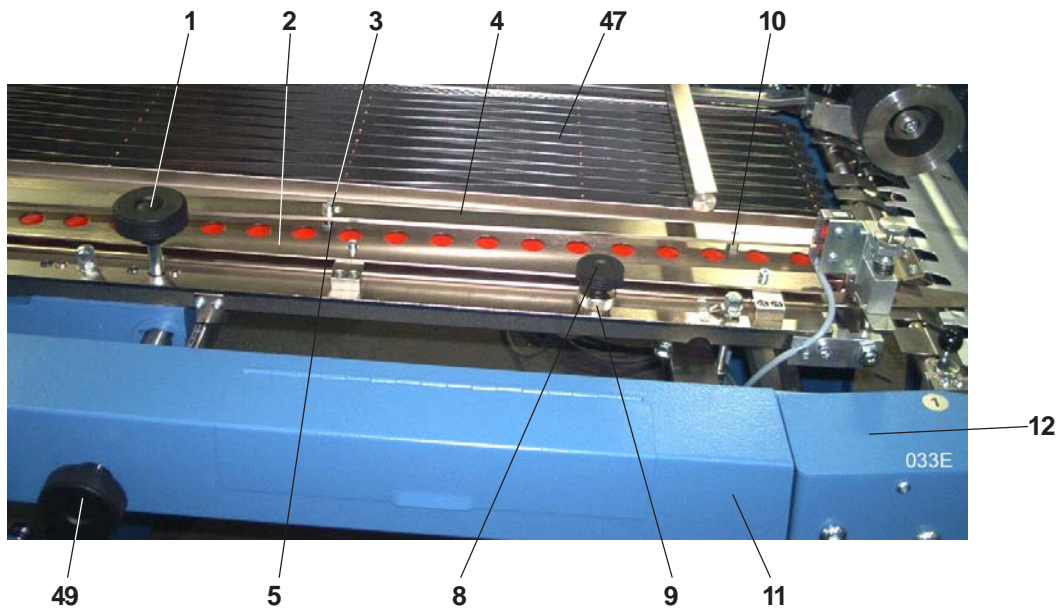

01	Screw		10.4200.02	
02	Ball bar		1.0.4262.311	
03	Screw		0088849.5	(M6 x25 DIN 912)
04	Ball holder bar		1.0.4241.310	
05	Nut		0090852.5	(M6 DIN 934)
06	Plastic ball		00110288	(20Ø)
07	Steel ball		00110262	(20Ø)
08	Knurled grip		00100269	(M8x40SW GN 534)
09	Excenter grip		1.0.4229.300	
10	Bolt		10 340 070	
11	Tool box		1.0.4161.310	
12	Guard		1.0.3162.420	
13	Pin		00093138	(3x8 DIN 1481)
14	Nut with Screw		0090837.5 0085878.5	(M4 DIN 934) (M4x25 DIN 84)
15	Angle		1.0.4541.300	
16	Microswitch		00126417	(S9)
17	Holder		10 490 150	
18	Bar	B26E	01.4121.02	
		B30E	01.4121.03	
19	Knurled screw		0087916.5	(M6x25 DIN 653)
20	Knurled nut		0087148.5	(M6 DIN 467)
21	Washer		0086132.5	(10.5 DIN 125)
22	Spring		20 480 150	
23	Bearing block		1.0.4544.300	
24	Lever		2.0.4543.011	
25	Nut		0090910.5	(M12 DIN 934)
26	Screw		0095935.5	(M5x10 ULS)
27	Knurled screw		0087833.5	(M5x12 DIN 653)
28	Nut		0092148.5	(M6 DIN 986)
29	Knurled nut		00095877	(M6 GN 420)
30	Holder		1.0.2344.330	
31	Washer		0086116.5	(6.4 DIN 125)
32	Washer		0095661.5	(6.4 DIN 9021)
33	Holder		1.0.2344.320 1.0.2344.310	Operator side Drive side
34	Spring		60 480 040	
35	Screw		0091085	(M6x60 DIN 938)
36	Knob		00086504	(C20xM5 DIN 319)
37	Blower tube		01.3726.01	
38	Bolt		2.0.4525.010	
39	Screw		0085795.5	(M4x10 DIN 84)
40	Feeler		10 300 042	
41	Screw		0085670.5	(M3x12 DIN 84)
42	Nut		0090852.5	(M6 DIN 934)
43	Screw		0089631.5	(M6x12 DIN 913)
44	Screw		0095240.5	(M4x8 DIN 7991)
45	Clip		1.0.2386.011	
46	Infeed plate	B26E	01.3163.00	Operator side
		B26E	01.3163.01	Drive side
		B30E	01.3163.02	Operator side
		B30E	01.3163.03	Drive side
47	Jalousie cpl.		01.4400.00	
48	Spring		20 480 181	
49	Star grip Screw		10 410 020 0089607.5	(M6x8 DIN 913)
50	Nut		0090837.5	(M4 DIN 934)

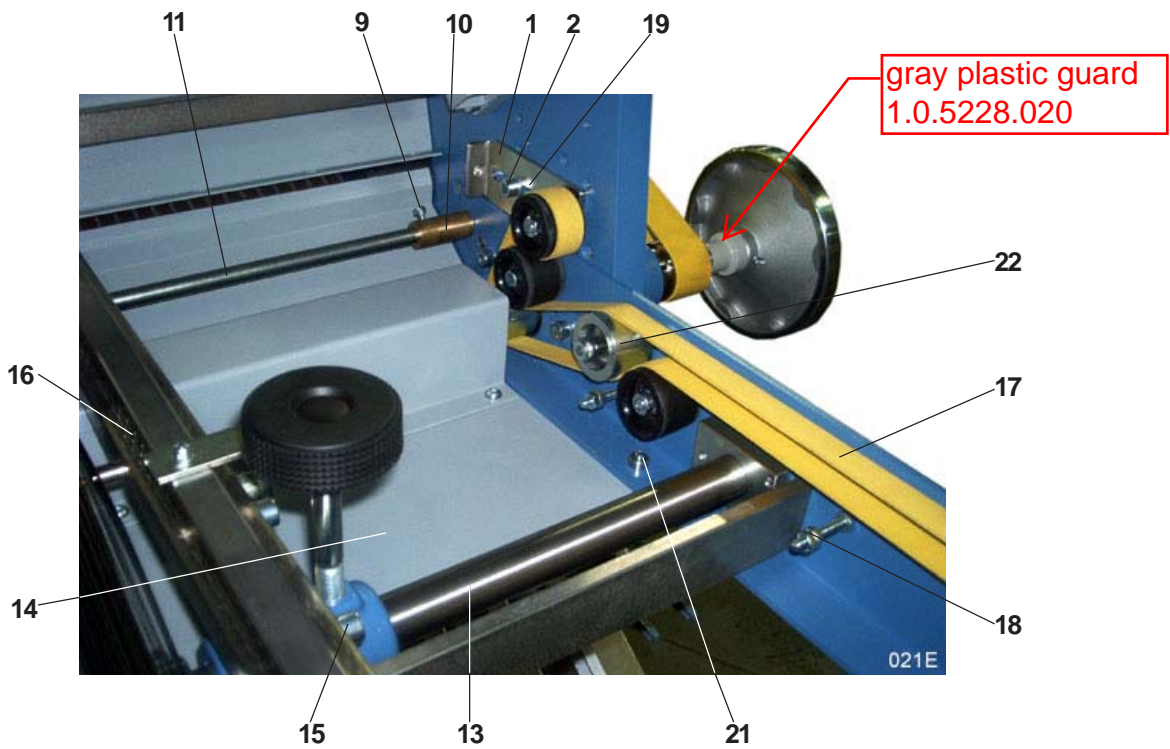
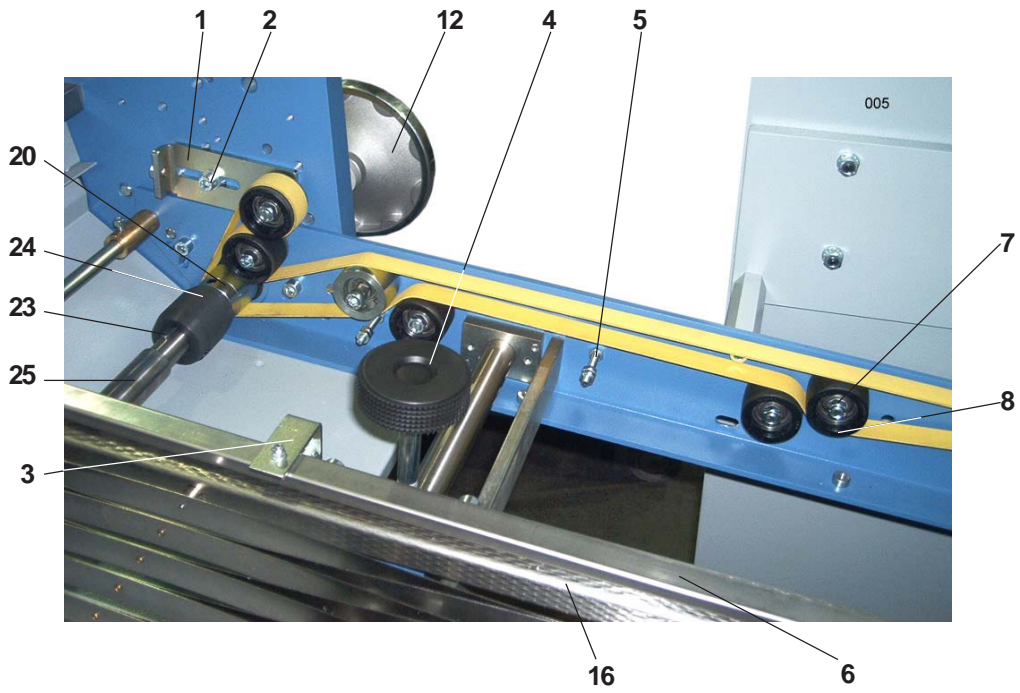

01	Holder		5.0.5244.011	
02	Screw		0088997.5	(M8x 20 DIN 912)
03	Holder		17.4264.00	
04	Screw		10.4200.02	
05	Screw		0090407.5	(M6x45 DIN 933)
06	Smoother		01.4253.005	
07	Screw		0089037.5	(M8x35 DIN 912)
08	Tape roller		00111781	(INA F56 202)
09	Screw		0088781.5	(M6x10 DIN 912)
10	Bush		1.0.4126.010	
11	Bar	B26E	01.4121.04	
		B30E	01.4121.05	
12	Handweel		00111906	(ZI 160x16)
13	Bar	B26E	01.4121.00	
		B30E	01.4121.01	
14	Guard	B26E	01.4161.00	
		B30E	01.4161.01	
15	Screw		0088682.5	(M5x20 DIN 912)
16			01.4263.001	
17	Flat belt		00105908	(20x2300 FU11)
18	Nut		0090852.5	(M6 DIN 934)
19	Washer		0086124.5	(8.4 DIN 125)
20	Tape roller		1.0.5232.360	
21	Nut		00095745	(M6 Anchor)
22	Tape roller		70 230 042	
23	Key		00094508	(6x6x30 DIN 6885)
24	Coupling		3.0.5326.024	
25	Handwheel shaft	B26E	01.5221.02 par.unit length 848mm	
		B30E	01.5221.04 par.unit length 948mm	

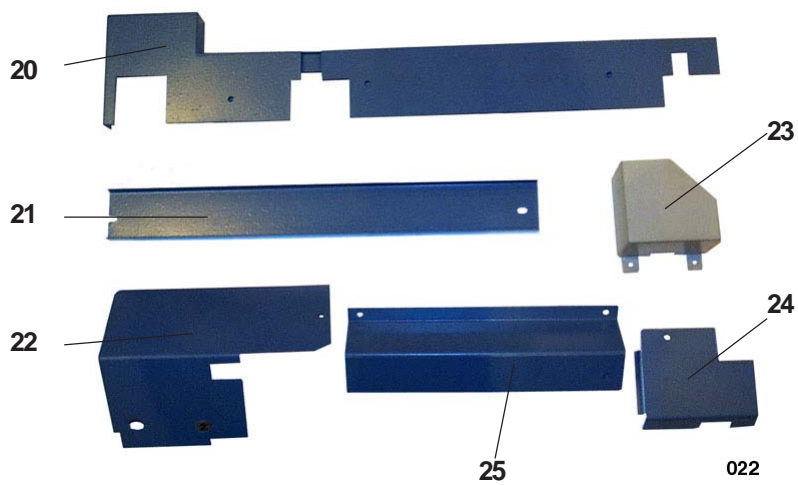
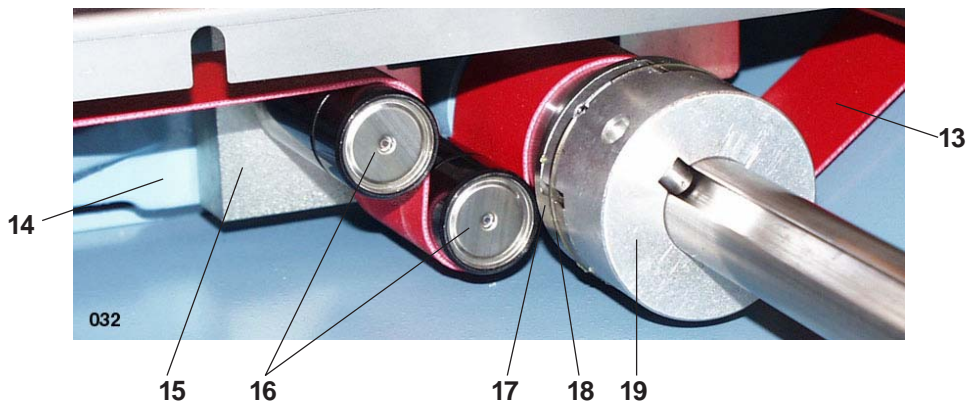
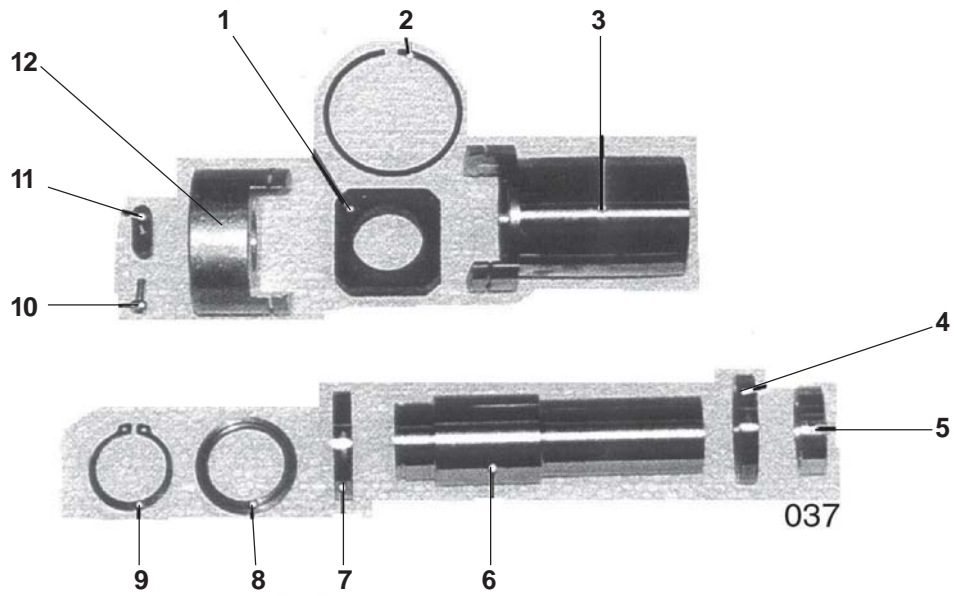

01	Coupling		5.0.4244.011	
02	Seegerring		00101402	(SW 55)
03	Tape roller		1.0.4232.340	
04	Ball bearing		00109918	(61806-2RZ)
05	Distance bush		1.0.4228.020	
06	Bearing bush		1.0.4226.320	
07	Ball bearing		00109918	(61806-2RZ)
08	Ring		5.0.4228.010	
09	Ring		00087312	(30x1,5 DIN 471)
10	Screw		0088583.5	(M4x10 DIN 912)
11	Key		5.0.4243.010	
12	Coupling part		5.0.4227.011	
13	Tape		0106924	(50x2100)
14	Holder		1.0.4211.330	
15	Holder		1.0.4244.310	
16	Roller		00111773	(FR 28x60x70)
17	Tape roller		1.0.4232.340	
18	Circlip		00101402	(SW 55)
19	Coupling		5.0.4227.011	
20	Guard		1.0.4161.340	
21	Guard	B26E	01.4161.04	
		B30E	01.4161.05	
22	Guard		01.3162.017	
23	Guard		1.0.2262.350	
24	Guard		1.0.2162.381	
25	Guard	B26E	01.4161.02	
		B30E	01.4161.03	

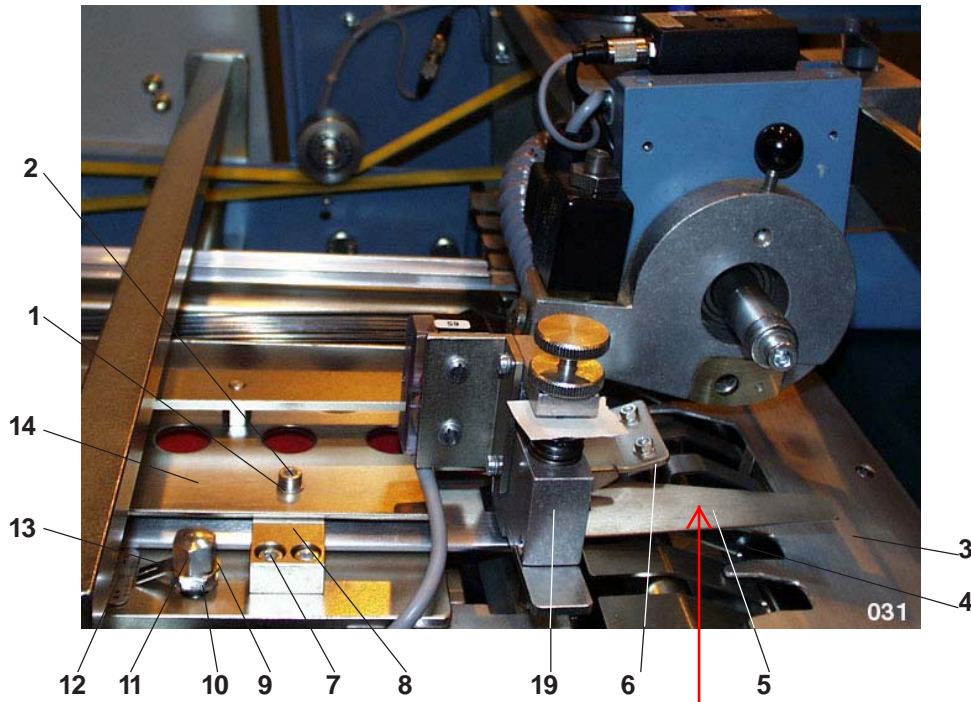

**HARDWARE TO
ATTACH GUIDE
PLATE
M4X10DIN7991
4.3DIN125
M4DIN934**

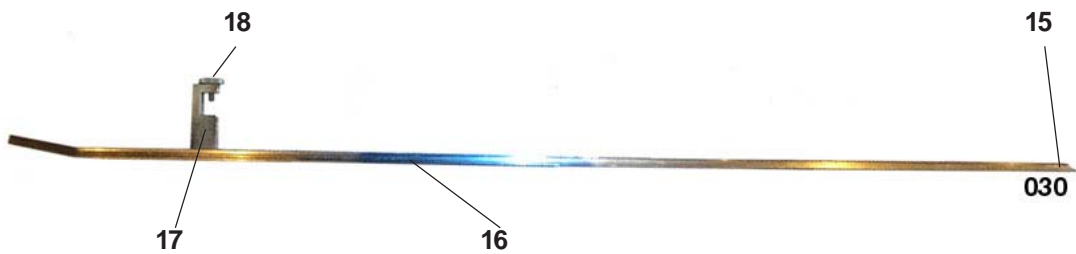

01	Washer		0086116.5	(6.4 DIN 125)
02	Screw		0088781.5	(M6x10 DIN 912)
03	Plate	B26E	01.3263.00	
		B30E	01.3263.01	
04	Plate		1.0.3562.020	
05	Guide plate		01.4263.002	
06	Infeed plate		1.0.4262.301	
07	Screw		0088641.5	(M5x10 DIN 912)
08	Holder		1.0.4244.330	
09	Washer		0086124.5	(8.4 DIN 125)
10	Nut		0090878.5	(M8 DIN 934)
11	Nut		0090084.5	(M8 DIN 917)
12	Scale		50 670 010	
13	Washer		0087062	(8,4 DIN463)
14	Ball bar		1.0.4262.311	
15	Flat spring		35.4285.00	
16	Smoother bar		01.4253.004	
17	Holder		1.0.4244.300	
18	Knurled screw		0087908.5	(M6x20 DIN 635)
19	Double sheet detector		1.0.4500.300	

#14	01.7261.046 FWII	in stainless steel	Ball Bar
	01.7261.045 FWIII	in stainless steel	Ball Bar

15-18 Smoother cpl. 01.4200.007

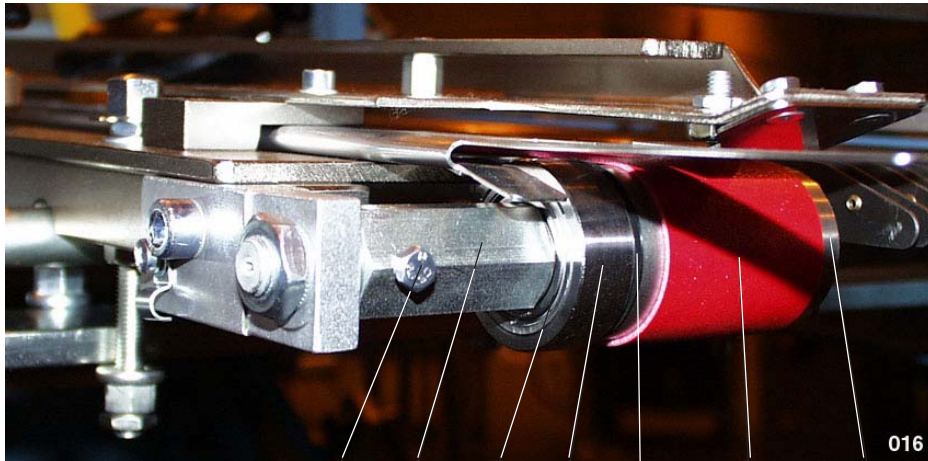

6 5 4 3 2 15 1

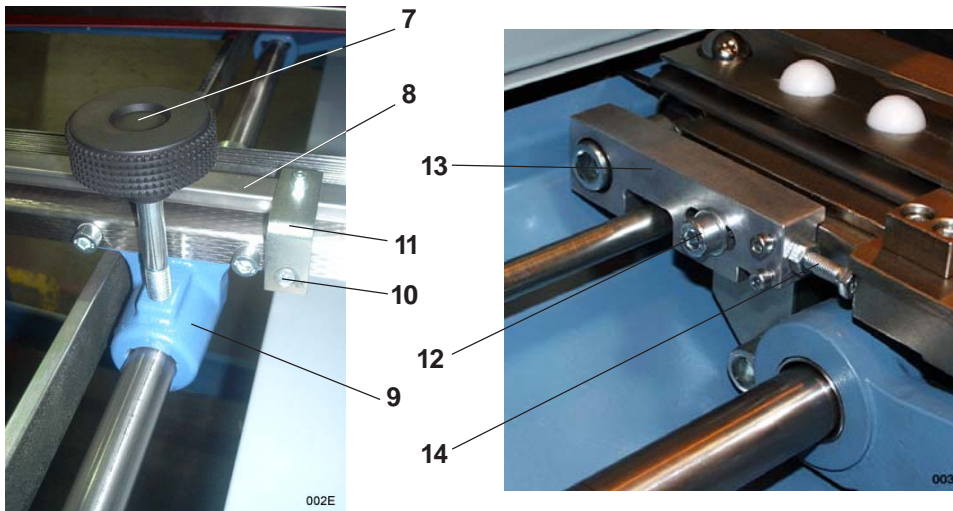

01	Tape roller	5.0.4232.041	
02	Washer spring	5.0.4283.010	
03	Roller	5.0.4231.010	
04	Ball bearing	00109686	(6003-2Z)
05	Bearing bolt	5.0.4225.011	
06	Screw	0090233.5	(M5x10 DIN 933)
07	Screw	10.4200.02	
08	Smoother	01.4253.005	
09	Holder	1.0.4211.320	
10	Screw	0088682.5	(M5x20 DIN 912)
11	Holder	17.4264.00	
12	Screw	0089003.5	(M8x25 DIN 912)
13	Holder	1.0.4244.320	
14	Screw	0090404.5	(M6x40 DIN 933)
15	Tape	0106924	(50x2100)
1-6	Tape roller cpl.	5.0.4200.100	

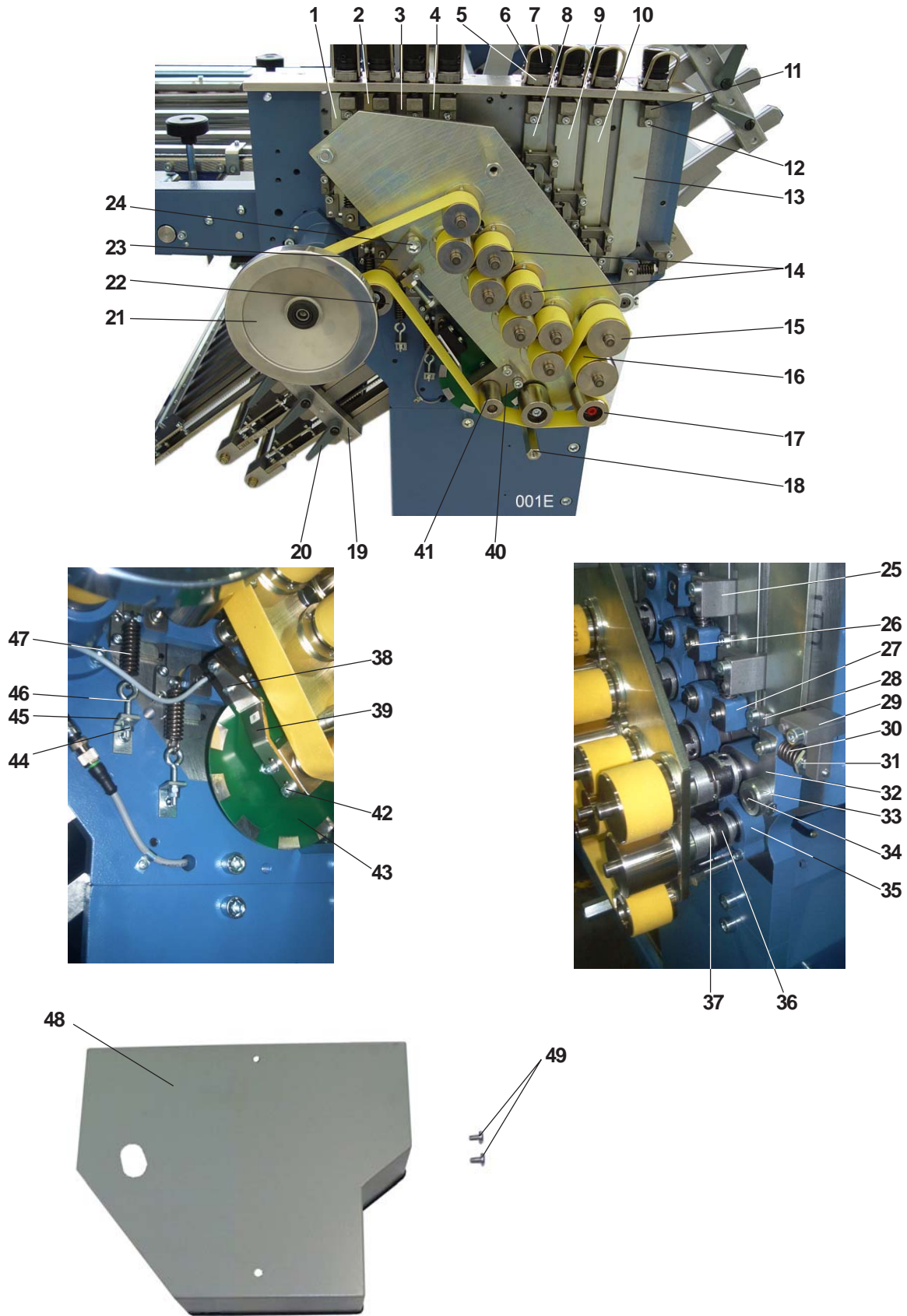

01	Adjustment part	01.5444.018	
02	Adjustment part	17.5444.03	
03	Adjustment part	17.5444.06	
04	Adjustment part	17.5444.08	
05	Pressure piece	1.0.5415.320	
06	Hoop	2.0.5486.010	
07	Grip with scaled ring	1.0.5428.010	
08	Adjustment part	17.5444.01	
09	Adjustment part	17.5444.04	
10	Adjustment part	17.5444.07	
11	Adjustment piece	1.0.5415.300	
12	Cylinder screw	0088799.5	(M6x12 DIN 912)
13	Adjustment part	17.5444.09	
14	Coupling cpl.	17.5200.169	
15	Coupling cpl.	17.5200.096	
16	Tape (4 buckle)	0540153	(PU35x1540)
	(6 buckle)	0540047	(PU35x1800)
17	Pulley	17.5232.039	
18	Nut	17.5125.009	
19	Clamping plate (4 buckle)	01.5100.116	
	Clamping plate (6 buckle)	01.5100.117	
20	Lever	5.0.5125.010	
21	Handwheel	00111906	(ZI 160x16)
22	Pulley	17.5232.039	
23	Holder	01.5244.013	
24	Cylinder screw	0089268.5	(M12x20 DIN 912)
25	Holder	1.0.5415.310	
26	Cylinder screw	0088666.5	(M5x16 DIN 912)
27	Bearing lever	01.5311.000	
28	Holder	1.0.5444.300	
29	Holder	1.0.5415.310	
30	Spring	50 480 080	
31	Bolt	5.0.5325.061	
32	Bearing lever	01.5311.002	
33	Colar	0088206.5	(A16 DIN 705)
34	Cylinder screw	5.0.5325.010	
35	Bearing block	35.5300.45	
36	Coupling	3.0.5226.010	
37	Circlips	3.0.5283.010	
38	Cylinder screw	0085845.5	(M4x20 DIN 84)
39	Holder	13.6244.06	
40	Holder	17.5244.019	
41	Pulley	01.5232.002	
42	Cylinder screw	0088658.5	(M5x12 DIN 912)
43	Disc slitinitator	01.5236.001	
44	Nut	0090845.5	(M5 DIN 394)
45	Holder	1.0.5443.300	
46	Ring screw	0101428.5	(M5x30 berrang)
47	Spring	0102761	(Z - 160l)
48	Guard 4 buckle	01.5161.033	
	Guard 6 buckle	01.5161.034	
49	Screw	0086017.5	(M10x16 DIN 85)

TYPO should be
 01.5200.096
 new # 01.5200.111

01.5300.060 bearing lever
 cpl

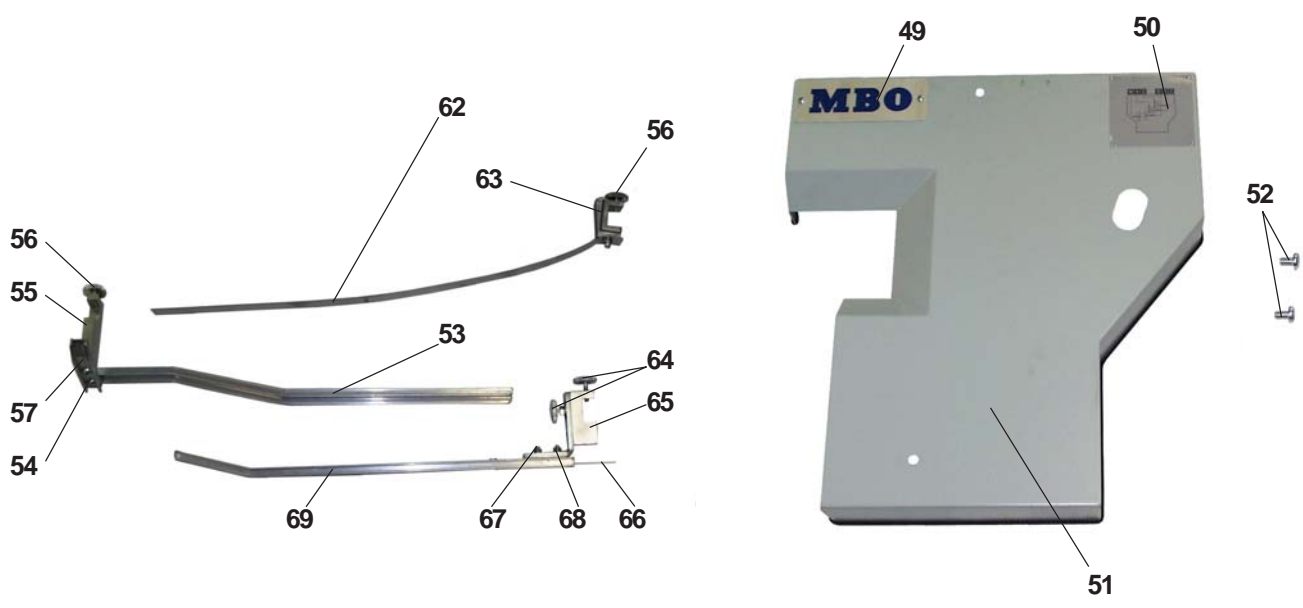
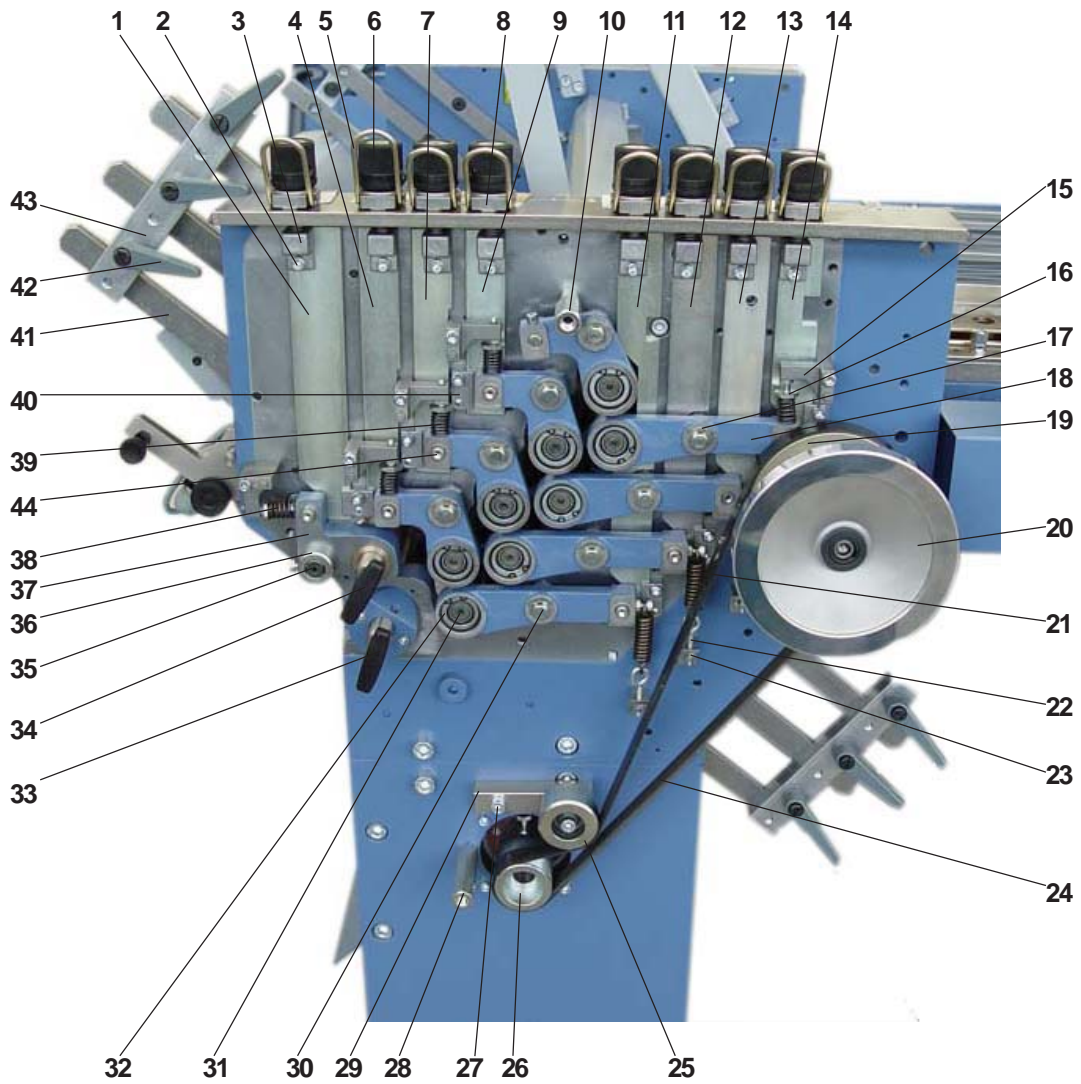

01	Adjustment piece	17.5444.09	
02	Cylinder screw	0088799.5	(M6x12 DIN 912)
03	Adjustment piece	1.0.5415.300	
04	Adjustment piece	17.5444.07	
05	Lever	2.0.5486.010	
06	Grip	1.0.5416.320	
07	Adjustment piece	17.5444.04	
08	Adjustment piece	1.0.5415.320	
09	Adjustment piece	17.5444.01	
10	Bolt	35.5125.00	
11	Adjustment piece	17.5444.08	
12	Adjustment piece	17.5444.06	
13	Adjustment piece	17.5444.03	
14	Adjustment piece	01.5444.018	
15	Holder	1.0.5415.310	
16	Bolt	5.0.5325.061	
17	Circlips	00101592	(12 SXN 09-R)
18	Bearing lever	17.5311.01	
19	pulley	1.0.5233.020	
20	Handwheel	00111906	(ZI 160x16)
21	Spring	0102761	(Z-160I)
22	Ring screw	0101428.5	(M5x30 Berang)
23	Holder	1.0.5443.300	
24	Poly-V-belt (parallel-4 buckles)	00107565	(380 J8 965 LW)
	Poly-V-belt (parallel-6 buckles)	00107608	(437 J8 1110 LW)
25	Belt tension lever	1.0.5200.350	
26	Pulley	1.0.5233.011	
27	Screw	0089011.5	(M8x30 DIN 912)
28	Bolt	1.0.5125.340	
29	Lever	3.0.6243.100	
30	Bolt	17.5325.01	
31	Ball Bearing	00109678	(6002-2RS1)
32	Ring	00087452	(32x1.2 DIN 472)
33	Bearing plug	01.5300.040	
34	Bearing plug	01.5300.060	
35	Cylinder screw	5.0.5325.010	
36	Colar	0088206.5	(DIN 705 A16)
37	Bearing lever	01.5311.002	01.5300.060 bearing lever complete
38	Spring	50 180 080	
39	Spring	00102947	(D254)
40	Holder	1.0.5444.310	
41	Buckle bar	01.5144.006	
42	Lever	5.0.5125.010	
43	Clamping plate (4buckle)	01.5100.116	
	Clamping plate (6buckle)	01.5100.117	
44	Cylinder screw	0088666.5	(M5x16 DIN 912)
45	Shield	17.5171.02	
46	Shield	1.0.5172.010	
47	Screw	0086017.2	(M10x16 DIN 85)
48	Guard B (4buckle)	01.5161.019	
	Guard B (6buckle)	01.5161.021	
49	Smoother	5.0.7151.020	
50	Screw	0096008.5	(M6x20 ULS)
51	Smoother	1.0.7351.320	
52	Holder	4.0.7144.020	
53	Knurled screw	0087882.5	(M6x12 DIN 653)
54	Smoother	01.7385.00	

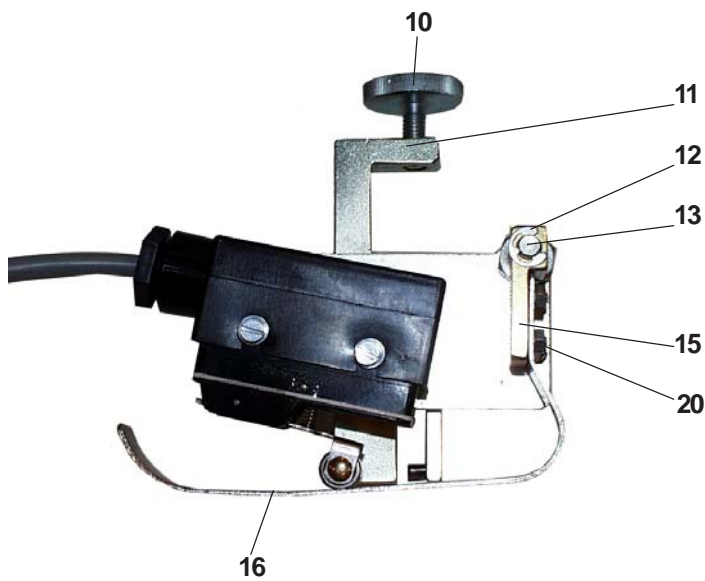
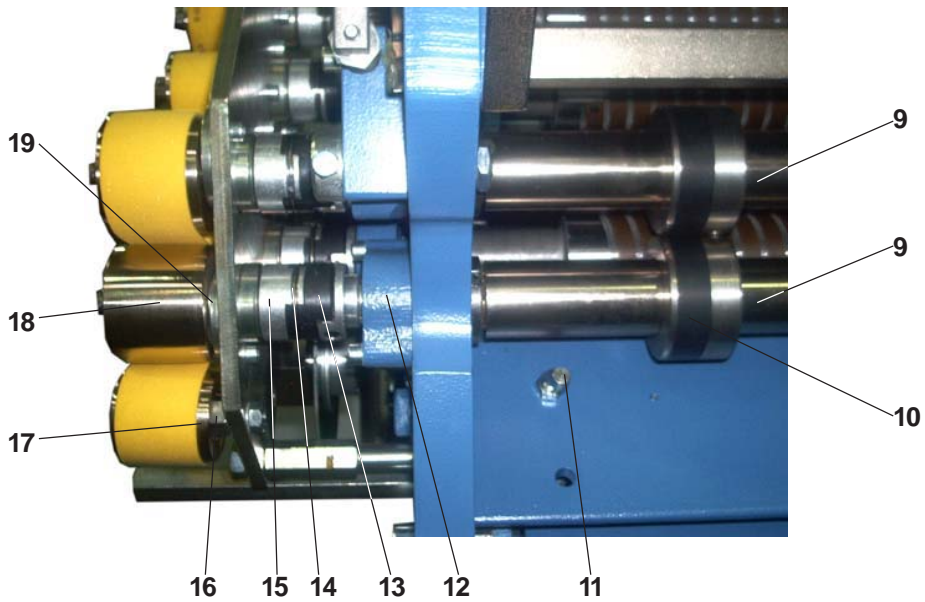

01	Flap	B26E	01.5761.13	
		B30E	01.5761.18	
02	Knurled		00101098	(GN 617.1-5-A)
03	Holder		01.5744.00	
04	Knurled grip		00100268	(GN 534-32-M6)
05	Bearing plug		01.5300.060	
06	Bearing plug		01.5300.040	
07	Screw		50 370 040	
08	Bearing bush		20.5326.002	
09	Slitter shaft	B26E	01.5300.048	
		B30E	01.5300.049	
10	Roller		01.5339.00	
11	Holler		1.0.5125.300	
12	Flange		1.0.5312.300	
13	Coupling		3.0.5226.010	
14	Circlips		3.0.5283.010	
15	Coupling piece		17.5226.04	
16	Distance ring		17.5228.009	
17	Pulley		17.5232.039	
18	Pulley		17.5232.037	
19	Bearing block		17.5227.22	
20	Knurled screw		0087874.5	(M6x12 DIN 653)
21	Bolt		20 340 130	
22	Circlips		0094185.5	(4 DIN 6799)
23	Bearing block		4.0.5544.110	
24	Screw		0091629.5	(M3x8 DIN 963)
25	Holder		01.5544.00	
26	Holder		01.5544.01	
27	Bracket		4.0.5585.060	
6-8	Bearing plug cpl.		01.5300.040	
10-20+24	Jam detector		01.5500.08	

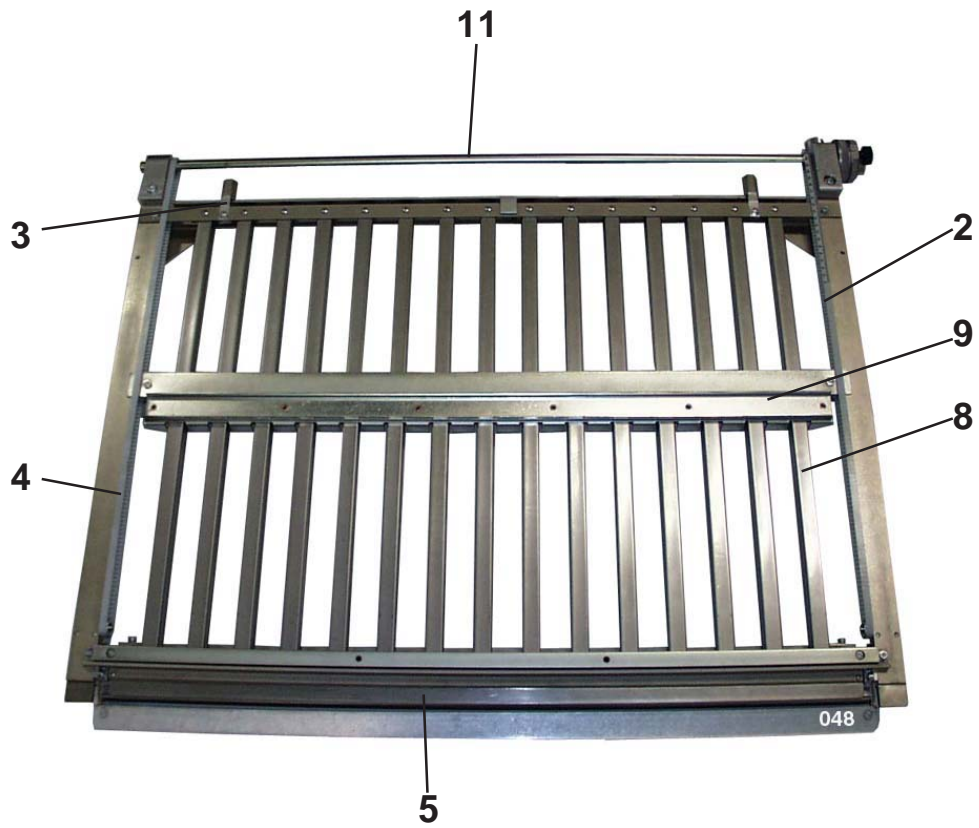

01 Holder				50 700 010 top buckle plate
Holder				50 700 020 bottom buckle plate
02 Scale belt par. unit buckle plate	No. 1.1 length „A“	778 mm/30 1/2"		01.5673.11 inch
	No. 2.1	648 mm/25 1/2"		01.5673.21 mm
	No. 1.3	488 mm/19"		01.5673.10 inch
	No. 4.1	488 mm/19"		01.5673.20 mm
	No. 2.1	648 mm/25 1/2"		01.5673.07 inch
8p unit	No. 2.2	648 mm/25 1/2"		01.5673.17 mm
	No. 2.3	488 mm/19 1/2"		01.5673.08 inch
	No. 4.2	488 mm/19"		01.5673.18 mm
	No. 2.1	648 mm/25 1/2"		01.5673.09 inch
16p unit	No. 2.2	648 mm/25 1/2"		01.5673.19 mm
	No. 2.3	488 mm/19 1/2"		01.5673.10 inch
	No. 4.2	488 mm/19"		01.5673.20 mm
	No. 3.1	488 mm/19"		01.5673.07 inch
	No. 2.3	488 mm/19"		01.5673.17 mm
	No. 3.3	488 mm/19"		01.5673.08 inch
	No. 3.3	488 mm/19"		01.5673.18 mm
	No. 4.3	488 mm/19"		01.5673.07 inch
	No. 4.3	488 mm/19"		01.5673.17 mm
	No. 4.3	488 mm/19"		01.5673.08 inch
32p unit	No. 4.1	488 mm/19"		01.5673.18 mm
	No. 2.4	388 mm/15"		01.5673.07 inch
				01.5673.17 mm
				01.5673.06 inch
				01.5673.16 mm
03 Flat spring				50 480 151
04 Timing belt	Length „A“	778 mm/30 1/2"		01.5673.03
		648 mm/25 1/2"		01.5673.02
		488 mm/19"		01.5673.01
		388 mm/15"		01.5673.00
05 Bottom plate lip		30"		01.5600.42
		26"		01.5600.41
		15"		01.5600.40
06 Holder				2.0.5644.030
07 Nut				50 410 021
08 Rail	Length „A“	778 mm/30 1/2"		1.0.5652.350
		648 mm/25 1/2"		1.0.5652.340
		488 mm/19"		1.0.5652.330
		388 mm/15"		1.0.5652.320
09 Sheet stop		30"		01.5651.02
		26"		01.5661.01
		15"		01.5661.00
10 Deflector		30"		01.5651.07
		26"		01.5651.11 with gluing device
				01.5651.06
				01.5651.10 with gluing device
		15"		01.5651.05
11 Bar		30"		01.5621.02
		26"		01.5621.01
		15"		01.5621.00
12 Top plate lip		30"		01.5600.32
				01.5600.46 with gluing device
		26"		01.5600.31
				01.5600.45 with gluing device
		15"		01.5600.30
13 Buckle rail	Length „A“	778 mm/30 1/2"		01.5641.11
		648 mm/25 1/2"		01.5641.09
		488 mm/19"		01.5641.07
14 Buckle rail	Length „A“	778 mm/30 1/2"		01.5641.12
		648 mm/25 1/2"		01.5641.10
		488 mm/19"		01.5641.08

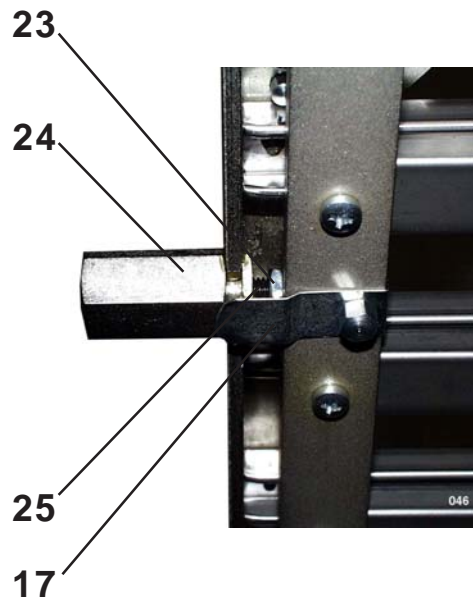
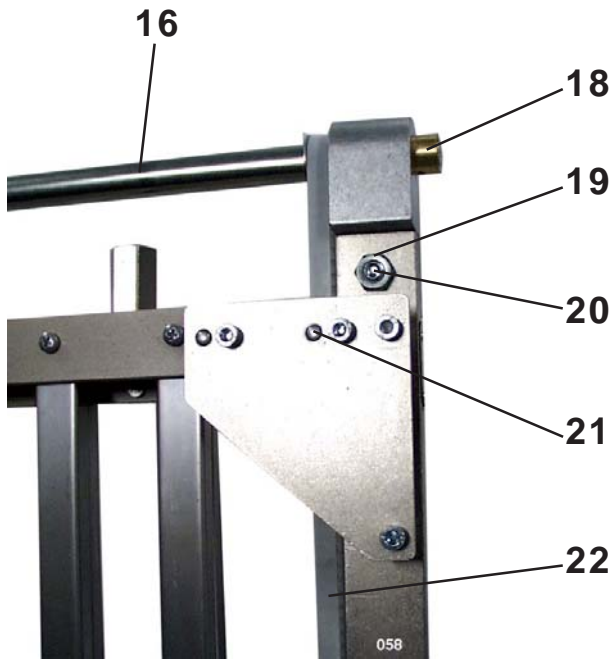
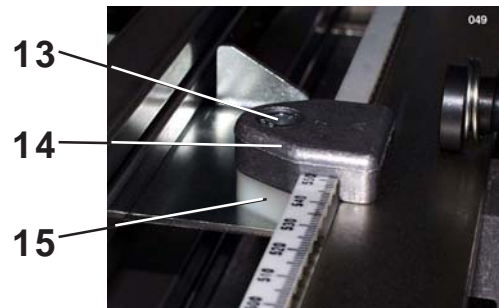
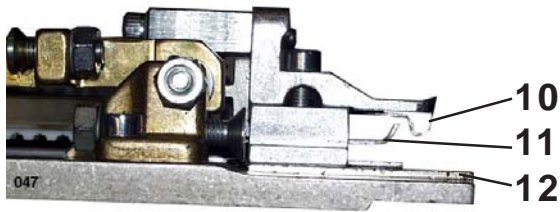
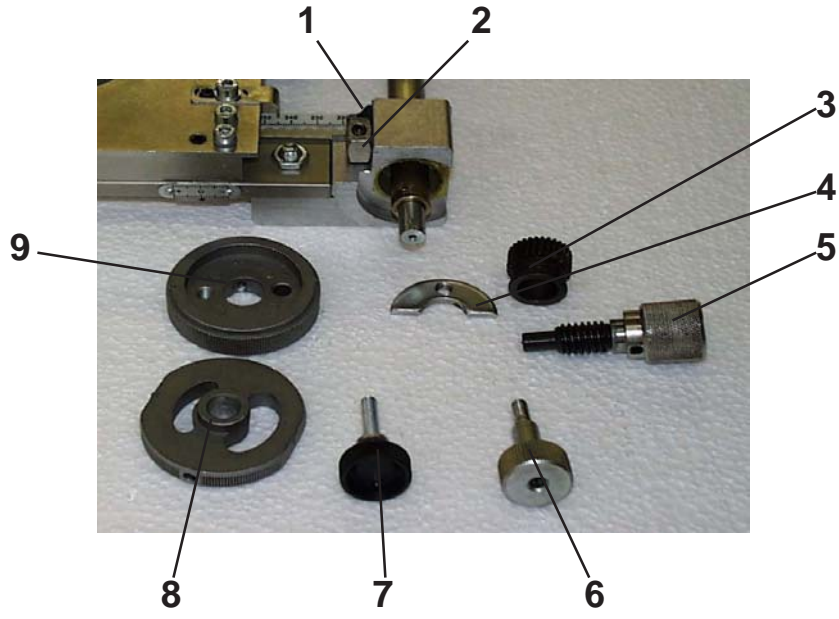

01	Flat spring		3.0.5686.010	
02	Ring		3.0.5628.060	
03	Worm gear		3.0.5637.010	
04	Washer		3.0.5628.032	
05	Temple ring		01.5628.01	
06	Screw		50 410 080	
07	Knurled screw		00095836	(M6x28 GN 421)
08	Ajustment washer		3.0.5628.020	
09	Ajustment washer		3.0.5628.010	
10	Top plate		01.5600.32	
11	Top plate		01.5600.37	
12	Bottom plate		01.5600.42	
13	Screw		0088823.5	(M6x20 DIN 912)
14	Holder		2.0.5644.041	
15	Holder		2.0.5644.051	
16	Bar		01.5621.03	
17	Flat spring		50 480 151	
18	Gear		2.0.5636.010	
19	Nut		0086876.5	(M8 DIN 934)
20	Screw		0094805.5	(M8x25 DIN 6912)
21	Pin		0093349	(5x10 DIN 1473)
22	Timing belt	Length „A“	778 mm/30 1/2"	01.5673.03
			648 mm/25 1/2"	01.5673.02
			488 mm/19"	01.5673.01
			388 mm/15"	01.5673.00
23	Nut		0086876.5	(M6 DIN 934)
24	Nut		50 410 021	
25	Screw		0094805.5	(M8x25 DIN 6912)

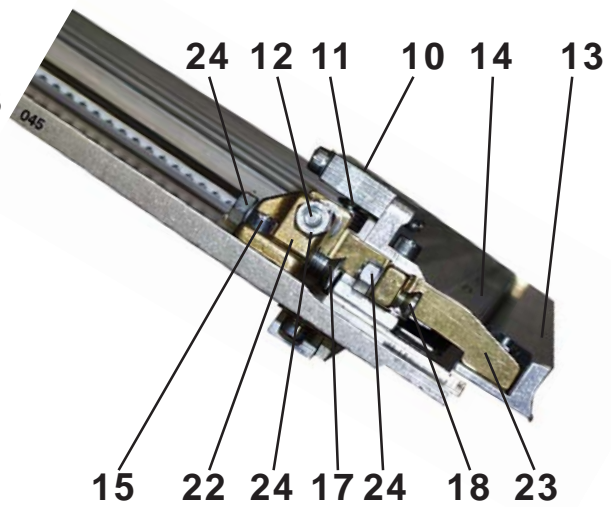
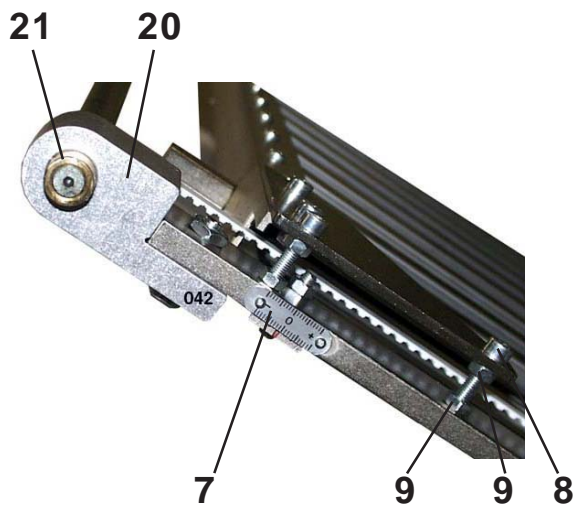
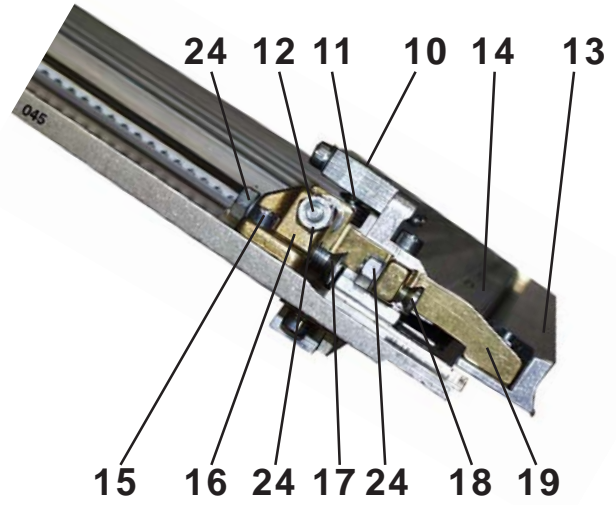
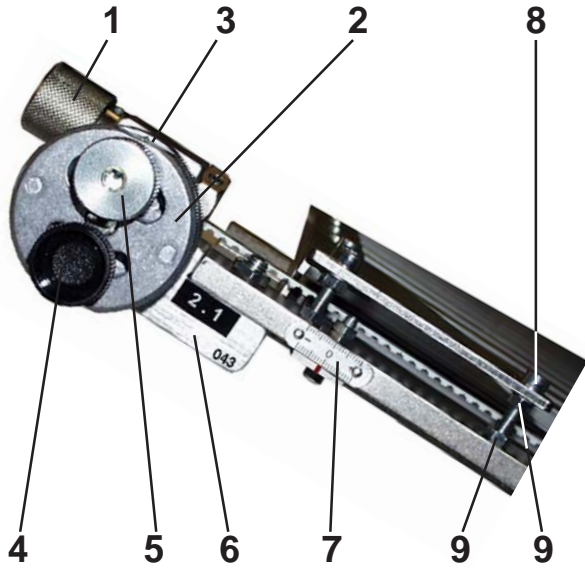

01	Knurled nut		01.5628.01	
02	Adjustment washer		3.0.5628.020	
03	Adjustment washer		3.0.5628.020	
04	Knurled screw		00095836	(M6x28 GN 421)
05	Screw		50 410 081	
06	Bearing block		50 700 010	Top buckle plate
06	Bearing block		50 700 020	Bottom buckle plate
07	Scale		50 670 010	
08	Screw		0088849.5	(M6x25 DIN 912)
09	Nut		0090845.5	(M5 DIN 934)
10	Screw		0095448.5	(M6x25 DIN 7991)
11	Spring		0102835	(D191)
12	Bolt		1.0.5625.010	
13	Deflector	B30E	01.5651.07	
			01.5651.11	with gluing device
		B26E	01.5651.06	
			01.5651.10	with gluing device
		16page unit	01.5651.05	
14	Top plate lip	B30E	01.5600.32	
			01.5600.46	with gluing device
		B26E	01.5600.31	
			01.5600.45	with gluing device
		16page unit	01.5600.30	
15	Screw		0088658.5	(M5x12 DIN 912)
16	Holder		1.0.5615.010	
17	Screw		0095463.5	(M6x35 DIN 7991)
18	Screw		1.0.5629.300	
19	Holder		1.0.5615.030	Top buckle plate
	Holder		1.0.5615.020	Bottom buckle plate
20	Holder		2.0.5644.030	
21	Bush		2.0.5636.010	
22	Holder		1.0.5615.010	
23	Holder		1.0.5615.020	Top buckle plate
	Holder		1.0.5615.030	Bottom buckle plate
24	Nut		0090852.5	(M6 DIN 934)

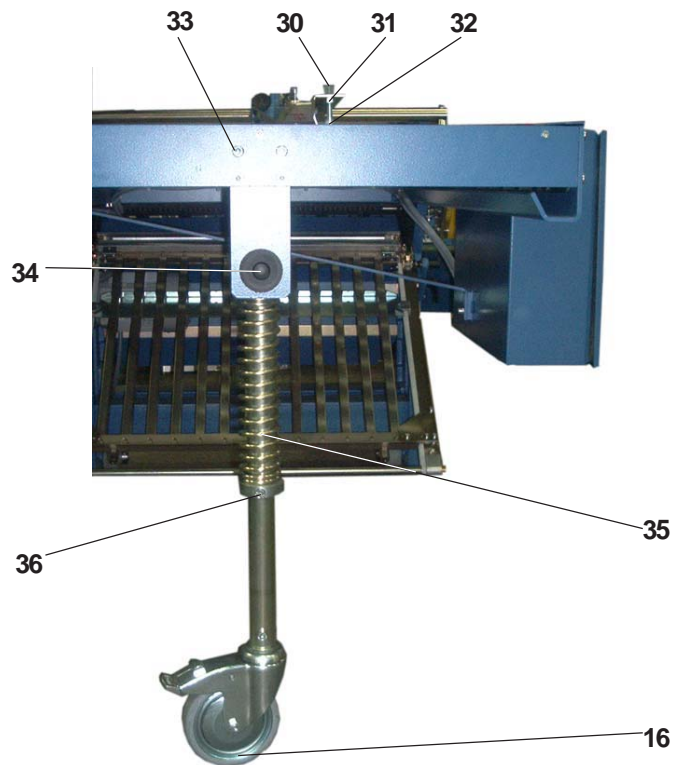
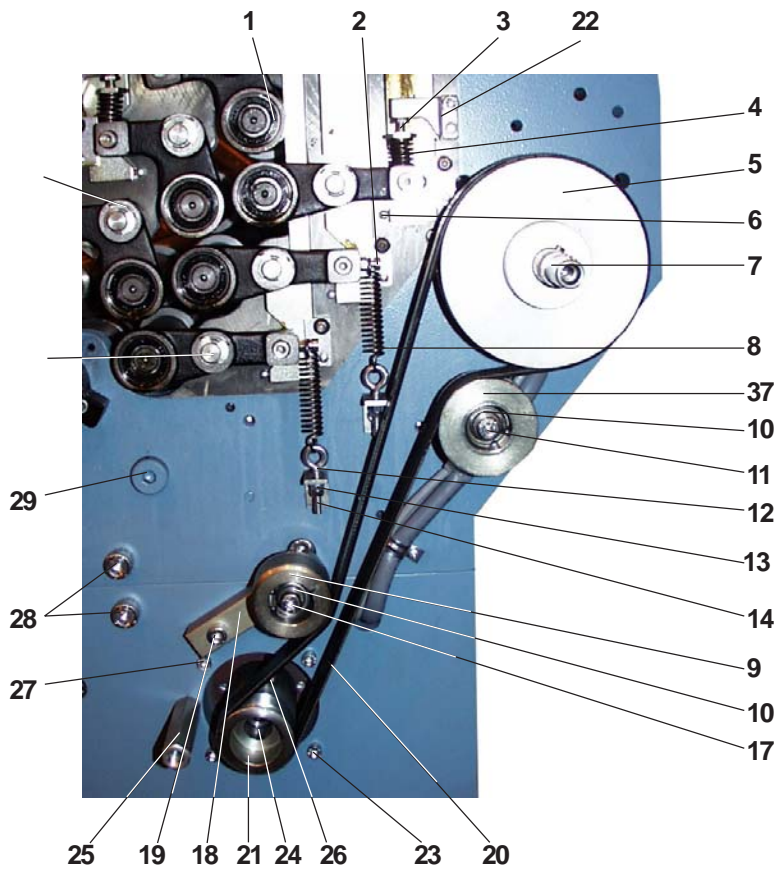

01	Ball bearing	00109678	(6002-2RS)
02	Screw	0088682.5	(M5x20 DIN 912)
03	Adjustment screw	5.0.5325.061	
04	Spring	00102947	(D254)
05	Pulley	1.0.5233.020	
06	Holder	1.0.5444.310	
07	Distance	1.0.5228.020	
08	Spring	00102761	(Z 160 I)
09	Pulley	1.0.5232.330	
10	Ball bearing	00111799	(F80.491 INA)
11	Screw	0088997.5	(M8x60 DIN 912)
12	Spring	00101428.5	(M5x30 GR.NO. 07300237-01)
13	Nut	0090845.5	(M5 DIN 934)
14	Angle	1.0.5443.300	
15	Circlips	00101592	(12 SXN 09-R)
16	Castor wheel	00104513	(125 RO5 Ø28x36)
17	Screw	0089037.5	(M8x35 DIN 912)
18	Lever	3.0.6243.100	
19	Screw	0089011.5	(M8x30 DIN 912)
20	Poly-V-belt	00107839	(400 J8 8/16 Page unit)
	Poly-V-belt	00107540	(340 J8 32 Page unit 2 plates)
21	Pulley	1.0.5233.011	
22	Holder	1.0.5415.310	
23	Screw	0088864.5	(M6x35 DIN 912)
24	Main motor	0103932	(0,75 kw)
25	Bolt	1.0.5125.340	
26	Screw	0090646.5	(M8x16 DIN 933)
27	Screw	0088864.5	(M6x35 DIN 912)
28	Screw	0089326.5	(M12x50 DIN 912)
29	Screw	00096339	(M12x16 h 8x40 UPS)
30	Nut	0090845.5	(M8 DIN 917)
31	Nut	0090878.5	(M8 DIN 934)
32	Screw	0089037.5	(M8x35 DIN 912)
33	Screw	0089003.5	(M8x25 DIN 912)
34	Star grip	00101857	(M8x18) / 50 370 044
35	Spring	70 480 010	
36	Screw	0088989.5	(M8x16 DIN 912)
37	Pulley	1.0.5232.380	

#24 correct part # 0103842

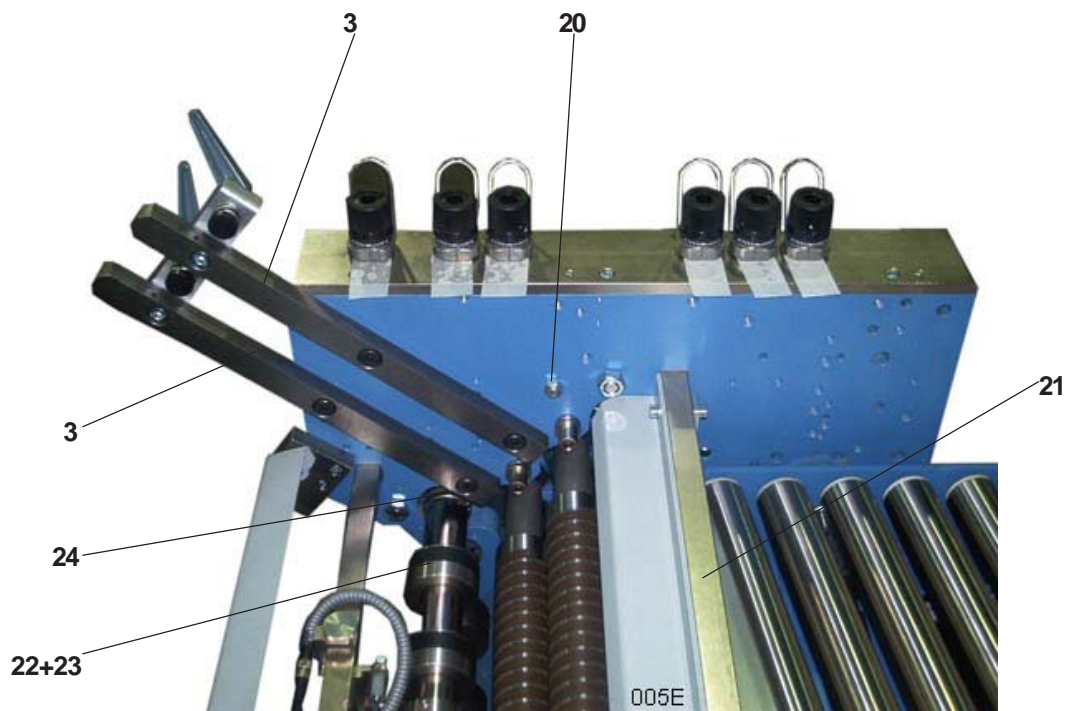
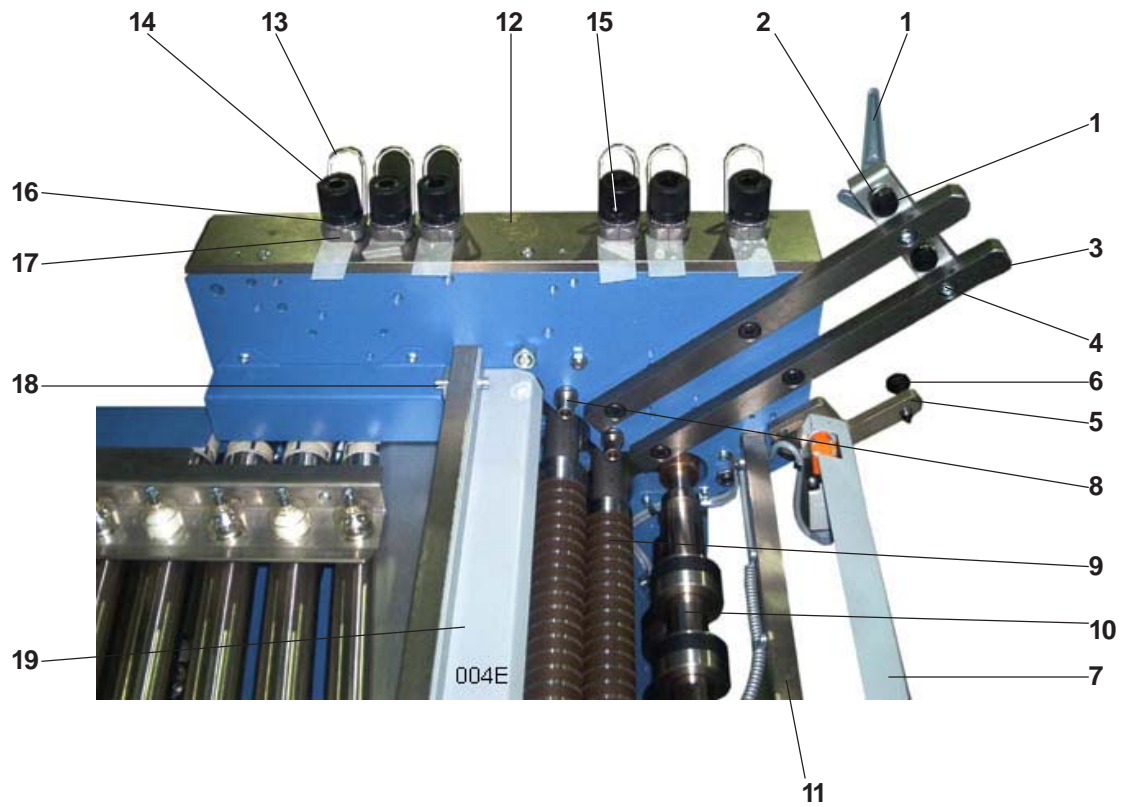

01	Lever		5.0.5125.010	
02	Spring		2.0.5681.010	
03	Buckle bar		01.5144.006	
04	Screw			(M8x25 DIN 6912)
05	Holder		01.5744.00	
06	Knurled		00101098	(GN 617.1-5-A)
07	Flap	B26E	01.5761.13	
		B30E	01.5761.18	
08	Nut		1.0.5329.310	
09	Fold roller	B26E	01.5300.02	(Parallel and 8page unit)
		B30E	01.5300.01	(Parallel and 8page unit)
			01.5300.00	(16page unit)
10	Perforation shaft	B26E	01.5300.048	(Parallel and 8page unit)
		B30E	01.5300.049	(Parallel and 8page unit)
			01.5300.58	(16page unit 15")
11	Bar	B30E	01.5141.02	(Parallel and 8page unit)
	Bar	B26E	01.5141.01	(Parallel and 8page unit)
12	Bar		01.5441.003	(6 plates)
	Bar		01.5441.001	(4 plates)
	Bar		01.5441.005	(2 plates)
13	Lever		2.0.5486.010	
14	Adjustment nut		1.0.5416.320	
15	Screw		4.0.5428.010	
16	Scale ring		1.0.5416.330	
17	Bearing block		1.0.5415.320	
18	Screw		0095976.5	(M6x10 ULS)
19	Guard	B26E	01.5161.05	
	Guard	B30E	01.5164.06	
		16page unit	01.5161.04	
20	Bolt		1.0.5325.050	
21	Bar	B30E	01.5141.05	(Parallel and 8page unit)
	Bar	B26E	01.5141.04	(Parallel and 8page unit)
	Bar		01.5141.03	(16page unit 15,,)
22	Roller		01.5339.00	
23	Screw		50 370 040	
24	Shaft		1.0.5325.380	

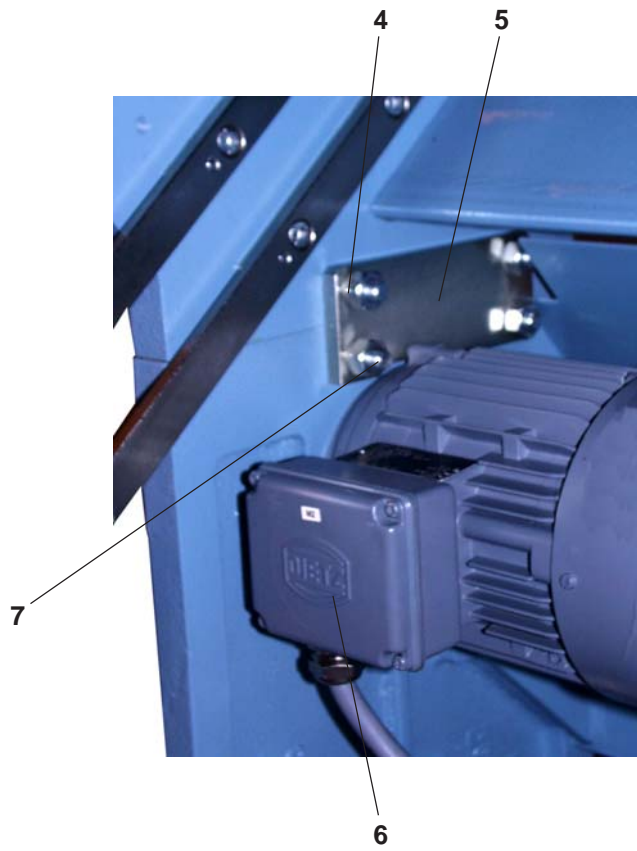

1	Guard	Parallel and 8pg B30E	01.7161.03	
		Parallel and 8pg B26E	01.7161.02	
		16page unit	01.7161.01	
2	Screw		0088989.5	(M8x16 DIN 912)
3	Wheel		00104588	
4	Nut		0090910.5	(M 12 DIN 934)
5	Holder		01.7144.00	(M12x35 DIN 603)
6	Main Motor		00103932	(0,75 kw = 3000u/min.)
7	Screw		0089326.5	(M12x50 DIN 912)

#6 correct part # 0103842

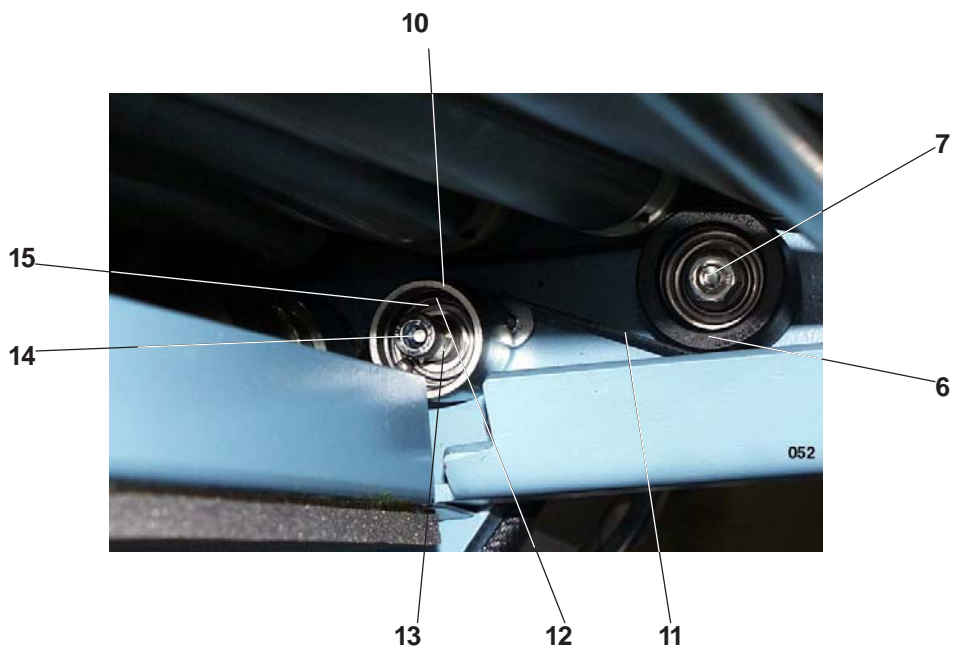
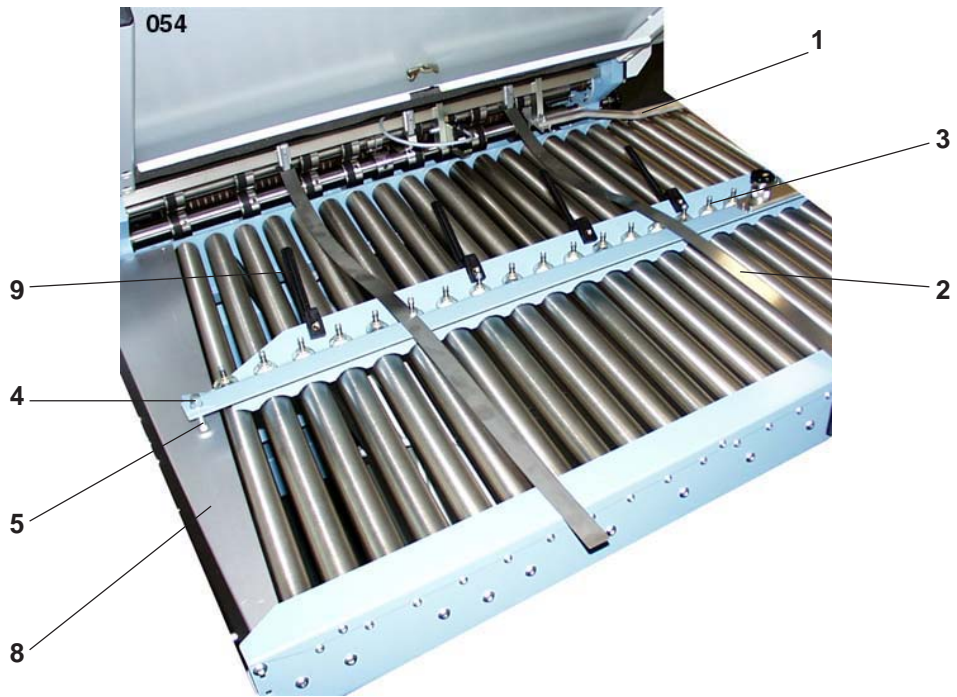

01	Smoother		1.0.7400.310	
02	Smoother	B26E	76 533 010	
		B30E	77 533 010	
03	Ball busch		5.0.7226.020	
04	Nut		0090845.5	(M8 DIN 917)
05	Screw		0089037.5	(M8x35 DIN 912)
06	Tape roller		00111781	(INA V56 202)
07	Nut		0086876.5	(M8 DIN 934)
08	Infeed plate	B26E	01.7363.08	
		B30E	01.7363.10	
09	Smoother		01.7264.00	
10	Tape roller		5.0.7332.010	
11	Flat belt		0090878.5	(20x3480 NE 17)
12	Circlip		00087429	(28x1,2 DIN 472)
13	Bolt		70 320 140	
14	Screw		0089052.5	(M8x45 DIN 912)
15	Ball bearing		00109645	(6001-2Z)
10+12-15	Tape roller cpl.		5.0.7300.210	

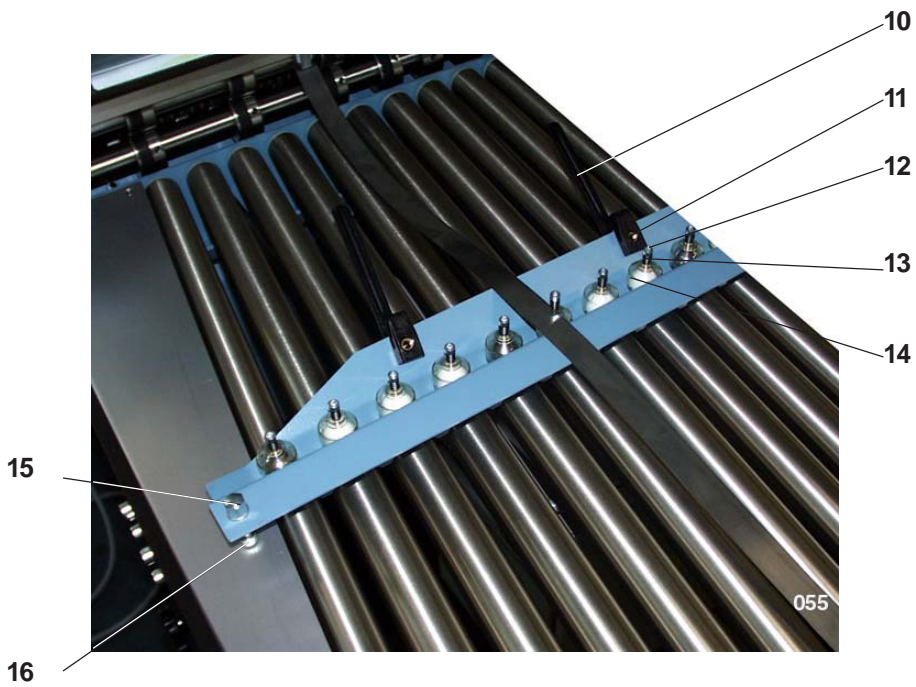
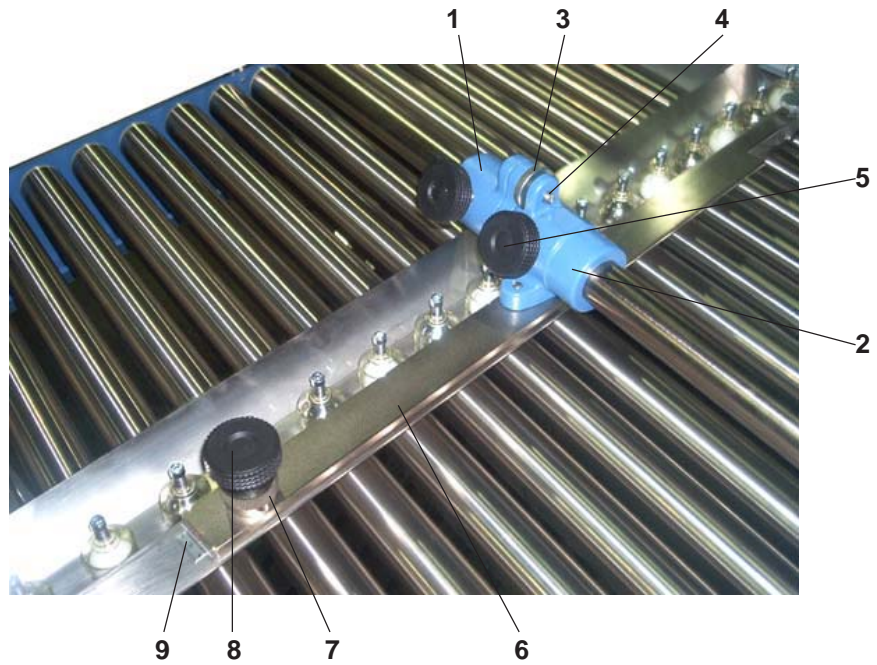

01	Adjustment piece	35.7212.01	
02	Adjustment piece	35.7212.00	
03	Knurled screw	0087155.5	(M8 DIN 467)
04	Screw	0091421.5	(M8x30 DIN 939)
05	Handle	13.2800.01	
06	Bar	2.0.7244.010	
07	Excenter grip	10 420 030	
08	Handle	00100266	(M8x40 GN 534)
09	Scale	50 670 010	
10	Smoother	01.7264.00	
11	Screw	50 370 040	
12	Screw	0088807.5	(M6x16 DIN 912)
13	Spring	00102681	(D128)
14	Ball bush	5.0.7226.020	
15	Nut	0090084.5	(M8 DIN 917)
16	Screw	0089037.5	(M8x35 DIN 912)
12-14	Ball holder cpl.	5.0.7200.220	

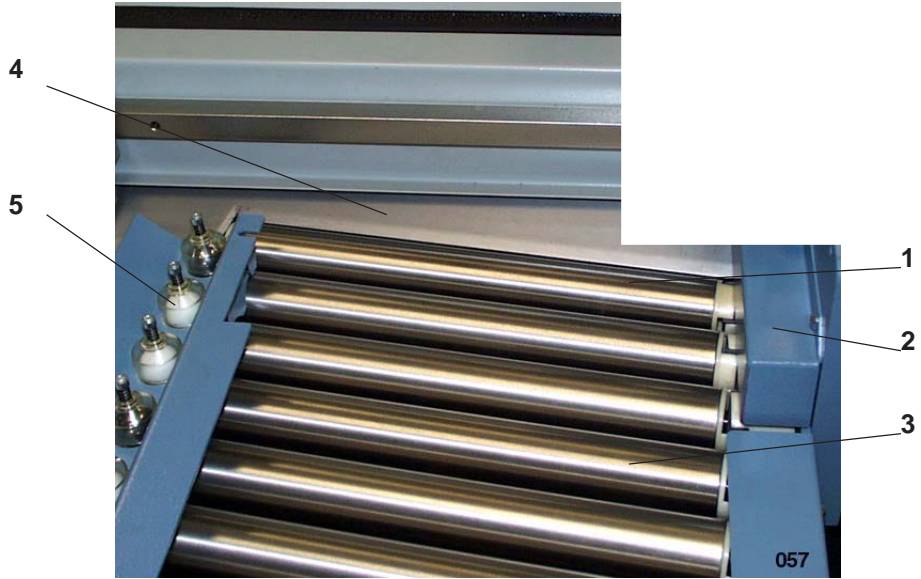

01	Roller		1.12.7400.100	
02	Guard		5.0.7362.021	
03	Roller	B26E	01.7400.31	
		B30E	01.7400.32	
04	Infeed plate	B26E	01.7363.07	
		B30E	01.7363.09	
05	Ball holder		5.0.7200.220	
06	Nut		0086876.5	(M8 DIN 934)
07	Tape roller		00111781	(INA V56 202)
08	Flat belt		00106179	(20x3480 NE17)
09	Holder		01.5264.00	
10	Screw		0088864.5	(M6x35 DIN 933)
11	Screw		0088989.5	(M8x16 DIN 912)

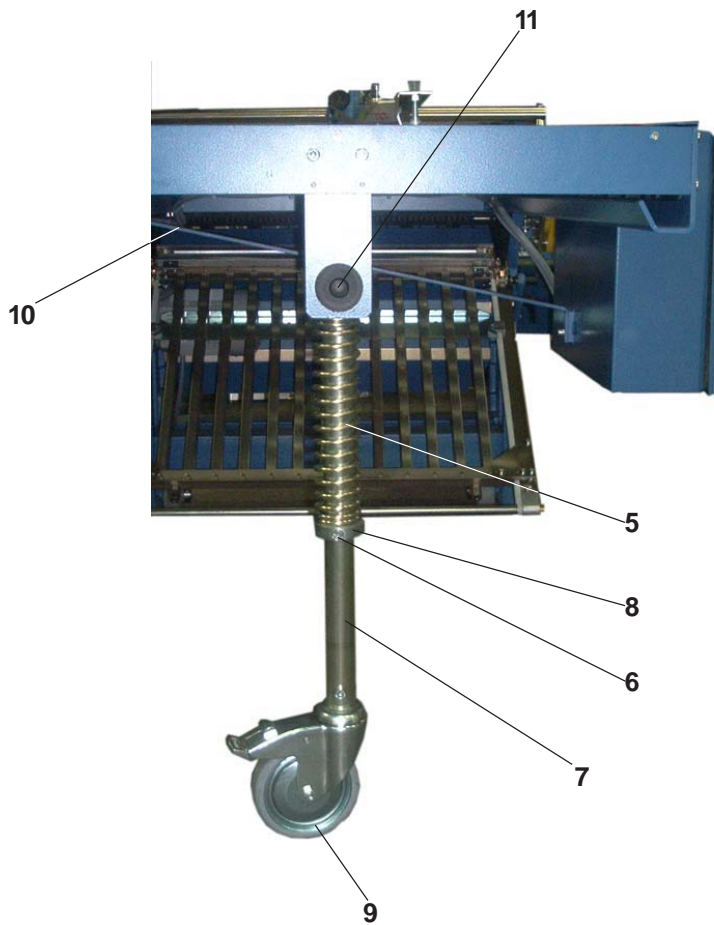
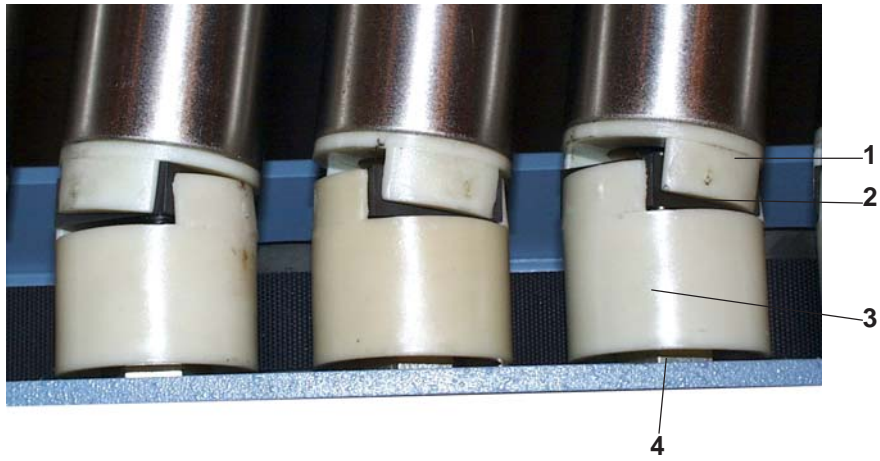

01	Roller	B26E	01.7400.31	
		B30E	01.7400.32	
			01.7400.30	(16page unit)
02	Coupling		70 640 011	
03	Tape roller		4.0.7400.020	
04	Bolt		4.0.7425.011	
05	Spring		70 480 010	
06	Screw		0088989.5	(M8x16 DIN 912)
07	Leg - length 445mm	16pg unit	4.0.7121.051	
	- lenght 580mm	8pg unit	4.0.7121.021	
08	Ring		0088443.5	(A35 DIN 705)
09	Casto wheel		00104513	(125 RO5 Ø28x36)
10	Bar	B26E	01.7344.004	
		B30E	01.7344.005	
11	Holder		81.8500.16	

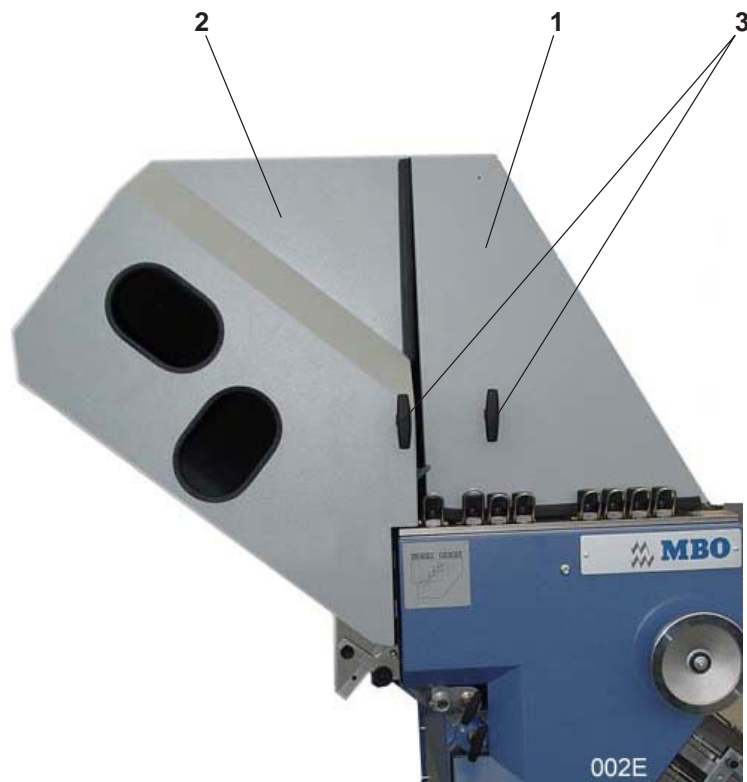
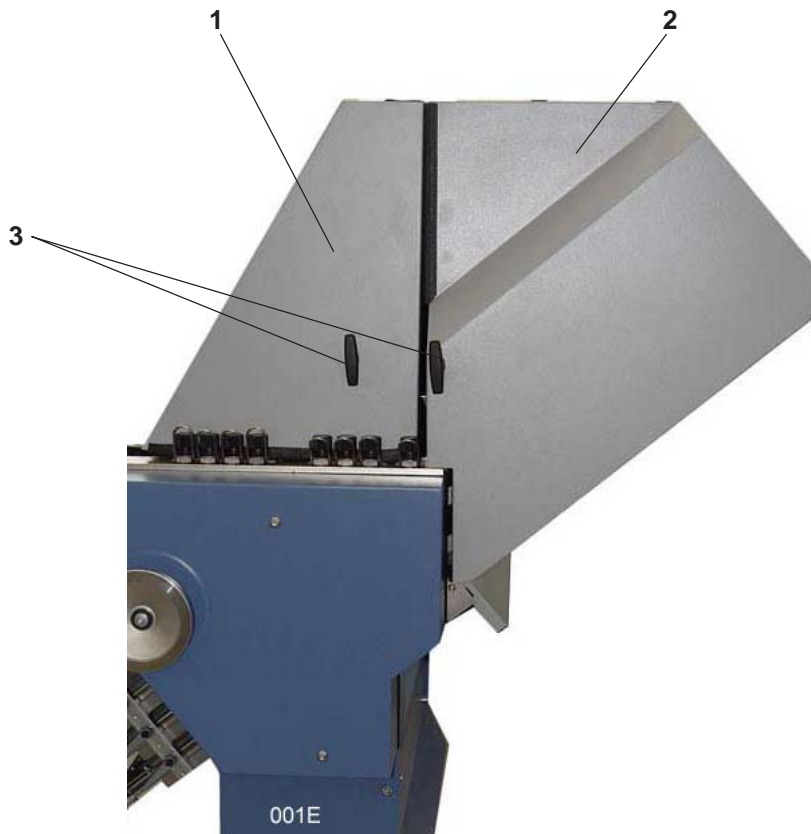

01	Noise hood	B26E (4 buckle)	01.5764.014	(parallel and 8page unit)
		B26E (6 buckle)	01.5764.014	(parallel and 8page unit)
		B30E (4 buckle)	01.5764.013	(parallel and 8page unit)
		B30E (6 buckle)	01.5764.013	(parallel and 8page unit)
02	Noise hood		01.5764.015	(16page and 32page unit)
		B26E (4 buckle)	01.5764.019	(parallel and 8page unit)
		B26E (6 buckle)	01.5764.017	(parallel and 8page unit)
		B30E (4 buckle)	01.5764.018	(parallel and 8page unit)
		B30E (6 buckle)	01.5764.016	(parallel and 8page unit)
03	Grip -T		01.5764.020	(16page unit)
			01.5764.021	(32page unit)
			00100255	(GN 563-80-M10)

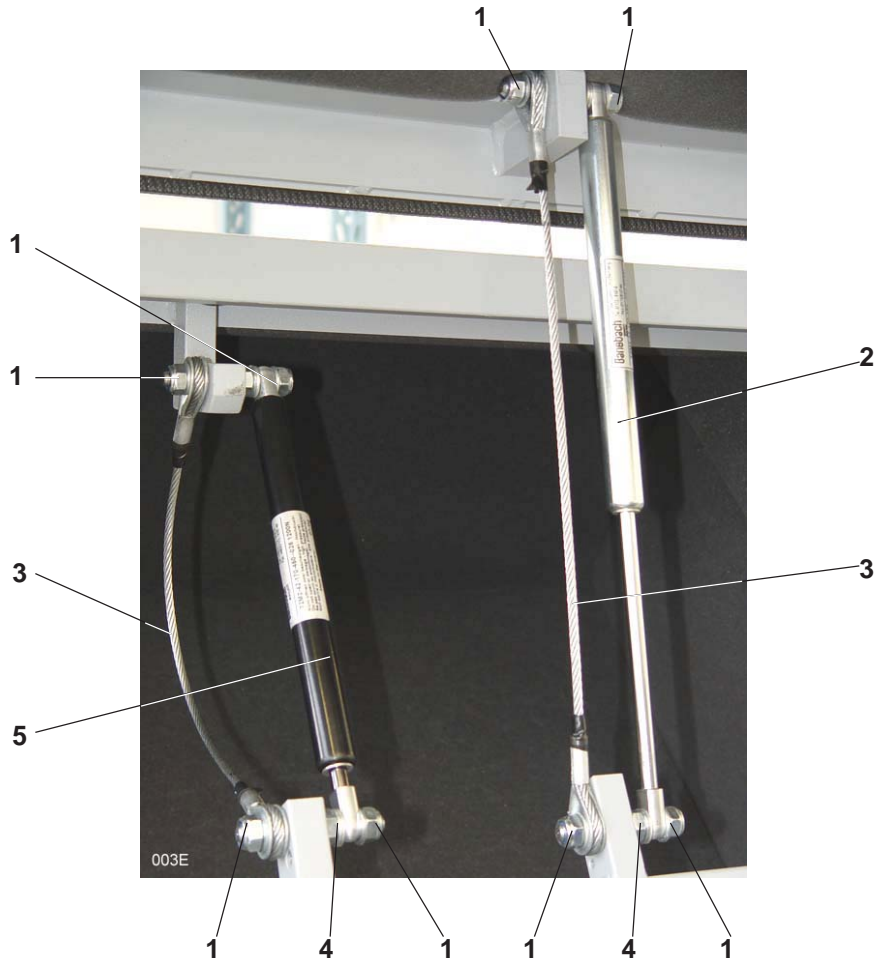

01	Nut		0092128	(M10 DIN 958)
02	Gas pressure spring	Parallel and 8 page	00100097	(T2M2-42-170-450/700N)
		16 and 32 page	00100119	(T2M2-42-170-450/900N)
03	wire		01.5708.000	
04	Nut		0090894.5	(M10 DIN 934)
05	Gas pressure spring	B26E (4 buckle)	00100123	(T2M2-42-170-450/1000N)
		B26E (6 buckle)	00100124	(T2M2-42-170-450/1100N)
		B30E (4 buckle)	00100125	(T2M2-42-170-450/1150N)
		B30E (6 buckle)	00100126	(T2M2-42-170-450/1200N)
		16page unit	00100121	(T2M2-42-170-450/950N)
		32page unit	00100119	(T2M2-42-170-450/900N)

MBO Portugal



MBO Binder
Máquinas Gráficas, S.A.
Rua Joaquim Alves da Silva 240, 420 e 570
4455-473 Perafita

Tel: (+351) 22 - 9982200
Fax: (+351) 22 - 9982201

info@mbo-folder.com

MBO Deutschland



MBO Binder GmbH & CO. KG
Postfach 1169
D-71567 Oppenweiler

Tel: (+49)(0)7191-46 0
Fax: (+49)(0)7191-46 34

<http://www.mbo-folder.com>
info@mbo-folder.com
