



MBO
Folding Technology

Operating Manual

Typen: FP 700 and FP 800

Palletized Feeder

Contents

Prologue	4
1.0 Machine specification	4
1.1 Manufacturer	4
1.2 Type:	4
1.3 Technical data	5
1.3.1 Sizes	5
1.3.2 Power requirements:	5
1.3.3 Operating speed:	5
1.3.4 Weights in kg:	5
1.4 Documentation	7
1.5 Supplementary documentation	8
1.6 User information / Functional description	9
2.0 BASIC SAFETY INSTRUCTIONS	10
2.1 Warnings and symbols	10
2.2 Safety at the working place - destined use of the feeder	10
2.3 Safety devices	12
2.3.1 Check list of protective hoods	12
2.3.2 Chart for protection hood of feeder and folding unit I	13
3.0 Transportation / Erection/Installation	14
3.1 Transportation	14
3.1.2 Cleaning	14
3.2 Erection/Installation	15
3.2.1 Feeder	15
3.2.2 Pressure/Vacuum pump	18
3.2.3 Guards	19
3.3 Electrical connection	20
3.3.1 Installation of main control panel	20
3.3.2 MC - Control	22
3.3.3 Main Power Connection	23

4.0	Service and maintenance	24
4.1	Exchange and/or tensioning of belts/tapes	25
4.1.1	Register belt at register table	25
4.1.2	Drive for Vacu-Infeed tape	26
4.1.3	Vacu-Infeed tape	26
4.1.4	Feeder - tensioning of drive chain	27
4.1.5	Feeder - final switch (top)	27
4.2	Lubrication/Cleaning	28
4.2.1	Feeder	28
4.2.2	Vaculift	28
4.2.3	Axe of pile plate	29
4.2.4	Register table	29
4.2.5	Pressure/Vacuum pump	30
4.2.6	Maintenance Report	31
5.0	Operation of the machine	32
5.1	Main control panel	32
5.2	Feeder	33
5.2.1	Manual piling	33
5.2.2	Pallet operation	34
5.2.3	Height control of pile and „Vaculift“	36
5.2.4	Feeder head „Vaculift“	37
5.2.5	Air support	38
5.2.6	Front air nozzles	39
5.2.7	Small sheet-size device	40
5.2.8	Vacu-Infeed	41
5.3	Register table	42
5.3.1	Vacu-Alignment	42
5.3.2	Double sheet control	43
5.4	Sheet infeed control	44
5.4.1	Automatic „learning“ of suction length and sheet gap	44
5.4.2	Photocells (Standard)	45
5.4.3	Photocells in folding units II and III (option)	46
6.0	Options	47
6.1	Batch counter	47
6.2	Other options	47
6.3	Final remarks	47

Prologue

By purchasing an MBO folding machine you have acquired a valuable product. However, it is absolutely imperative that all Safety Regulations and Safety Instructions are complied with fully. This Operating Manual will help to instruct you on how to correctly operate the feeder, to comply with the Safety Regulations and also how to maintain the machine properly.

1.0 Machine specification

1.1 Manufacturer

MBO Binder & Co. - Maschinenbau Oppenweiler
Grabenstrasse 4, 71570 Oppenweiler
P.O. Box 1169, D-71567 Oppenweiler
☎ +49 7191 46 0
Fax +49 7191 4634
<http://www.mbo-folder.com>

1.2 Type:

Palletized feeder FP 700 and FP 800

1.3 Technical data

1.3.1 Sizes

	FP 700	FP 800
Maximum open sheet size:	69 x 120 cm (27x47¼")	83 x 120 cm (32½ x 47¼") 88 x 120 cm* (34½ x 47¼")
Minimum open sheet size: (incl. small sheet size device)	17 x 25 cm (6½ x 9¾") 17 x 17 cm (6½ x 6½")	17 x 25 cm (6½ x 9¾") 17 x 17 cm (6½ x 6½")
Pile height:		95 cm (37¼") (Option: 120 cm/47¼")

1.3.2 Power requirements:

Feeder:	0.75 KW	0.75 KW
Air pump:	3.6 - 4 KW	3.6 - 4 KW

1.3.3 Operating speed:

10-205 m/min

1.3.4 Weights in kg:

	Net	Gross
Feeder FP 700:	800	1.000
Feeder FP 800:	800	1.000

*On request

1.3.5 Floor plan (measurements in cm):

FP 700/800

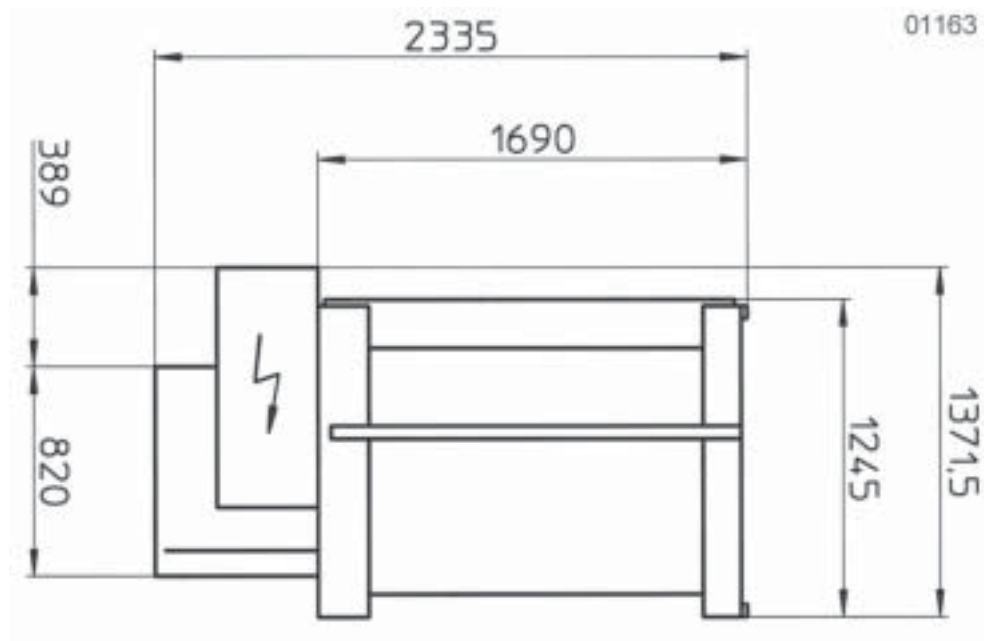

1.4 Documentation

Customer: _____

Machine no / Serial no: _____

Type of feeder: **Palletized feeder** _____

Type of air pump: _____

Electrical specifications: _____

Wiring diagram no: _____

Feeder: _____

Operational voltage (V / Hz): _____

Control voltage (V / A): _____

Control voltage (V / A): _____

Total nominal current (A): _____

Fuse at power supply (A): _____

Certificate of Conformity: _____

GS - marking no: _____

1.5 Supplementary documentation

Operating Manual of air pump: _____

Operating Manual of other manufacturers: _____

Spare parts lists: _____

Feeder: _____

Air pump: _____

Other manufacturers: _____

1.6 User information / Functional description

SHEET FEEDER for OPEN SHEETS

The feeder is designed to feed open sheets only. Feeding of any other material should not be attempted. The manufacturer or supplier will not be liable for any damage caused as a result.

Furthermore, the manufacturer will also not be liable for any malfunctions or damage of additional installations or alterations that were not delivered or installed by him.

The construction of your feeder may differ in some details from the photographs/diagrams shown. However, this does not have any influence on its safe operation. Since we are continuously working on further developments, we reserve the right to make alterations.

The production speed varies between 10 and 205 metres/minute. However, the efficiency depends on the type of paper, size, and type of fold, as well as on the different circumstances of the user which cannot be influenced by the manufacturer.

The following description should impart a general understanding of the feeder and its working method to the operator.

Please be advised that due to technical reasons and for better understanding certain options are already described in the standard feeder description.

The feeder basically consists of the basic frame, the upper and lower table including transport tapes, drum with tapes and chains, suction tape for sheet infeed, register table with suction tape for sheet alignment, and double sheet control.

2.0 BASIC SAFETY INSTRUCTIONS

2.1 Warnings and symbols

The following designations or symbols are used for very special instructions in this Operating Manual:



>**NOTICE**< Special instructions in respect of the economical use of the machine.



>**ATTENTION**< Special instructions or requirements and prohibitions to avoid injuries and damage.



>**DANGER**< Instructions or requirements and prohibitions to prevent personal injuries or extensive damage.

2.2 Safety at the working place - destined use of the feeder

- 2.2.1 MBO sheet feeders correspond to their prescribed Safety Technical Requirement at the time of their shipment. Therefore, any moveable and rotating parts are covered with protective hoods and are mechanically or electrically interlocked to such an extent so as to not unreasonably detract from the operation.
- 2.2.2 For safety reasons it is extremely important that all operating personnel receive sufficient technical safety instructions and are advised of all potential sources of danger. However, it must be remembered that even with proper use of the machine, accidents can occur which present a danger to life and limb of the operator or third parties. Respectively, it does not exclude the deduction of the machine and other material assets.
- 2.2.3 The feeder should only be operated when in good working order. Any malfunctions which may impair the safety must be removed immediately by trained personnel of the manufacturer/supplier.
- 2.2.4 The feeder is exclusively destined to feed sheets. The feeding of any other material should not be attempted as the manufacturer or supplier will not be liable for any damage caused thereof.
- 2.2.5 Carefully read the complete Operating Manual including the Safety and Service Requirements before you operate the feeder.
- 2.2.6 The Operating Manual should be kept with the feeder at all times.
- 2.2.7 Add to the Operating Manual if necessary, with internal Safety Instructions as well as with the legal regulations for the Prevention of Accidents.
- 2.2.8 Make sure that all frequently substituted operators are thoroughly informed about the aforementioned subjects and trained accordingly.

2.2.9 Never remove any protective or safety devices from the feeder, and do not make any changes which may impair the safety of the feeder.

2.2.10



>**DANGER**< Never use any tools which are not in perfect condition, and make sure that no tools are left on the feeder after completion of settings and maintenance work. Tools which fall into the feeder may cause serious injuries and damage.

2.2.11

Note that all Safety Instructions are kept in a legible and visible condition.

2.2.12

Any audible and visible change on the feeder in relation to the safety must be reported to the supervisor or manager of your company immediately.

2.2.13

The operating personnel should be aware that loose clothing, jewellery or (long?) hair can cause serious injuries if caught in the feeder.

2.2.14

It is absolutely prohibited to clean rollers, eliminate malfunctions, or to undertake adjustments while the feeder is on operation.



>**DANGER**< Therefore, always activate the EMERGENCY STOP button.

2.2.15

Make sure that no other person starts the feeder while you are working on it!



>**DANGER**< Therefore, always activate the EMERGENCY STOP button, or turn OFF the main switch, or UNPLUG.

2.2.16

Do not turn the feeder ON if it has stopped for any inexplicable reason. Make sure that the feeder is in good working condition and that no other person is working on the feeder.

2.2.17

Turn off the main switch and secure it, if necessary, with a lock if you are required to undertake extensive mechanical or electrical maintenance and repair work.

2.2.18

Never open the main or subcontrol panel! Only authorised personnel should gain access to the electronic control cabinets as there are no user serviceable parts.



>**DANGER**< If control cabinet is open! All main terminals could be alive even though the main switch has been turned off.

2.2.19

Any damaged cables or electrical connections must be reported to the competent authorities of your company.

2.2.20

Machine connections must be installed in such a manner that no cables, tubes or hoses are left trailing.

2.3 Safety devices

2.3.1 Check list of protective hoods

POS.	Benennung	Function - control	Visual - control	Result	Result
6	Guard over the drive of suction tape or wheel				at drive side
8	Guard over the suction tape or wheel				
9	Guard angle in front of suction tape or wheel				See for setting instruction on page of Operating Manual
22	Guard over the drive shaft of the suction wheel				suction wheel and suction tape
23	Guard over the pulley of the suction wheel				suction wheel and suction tape
24	Guard over the chain guide				
25	Guard over the switch gear				at drive side
26	Guard over the drive chain				at drive side
27	Guard over the feeder's drive shaft				at drive side
28	Guard over the Vaculift				
29	Guard over the motor for Vaculift				
30	Guard over the chain guide				
31	Pile plate				automatic stop as soon as the pile plate is 120 mm above the floor
	Date	Name		Signature	

2.3.2 Chart for protection hood of feeder and folding unit I

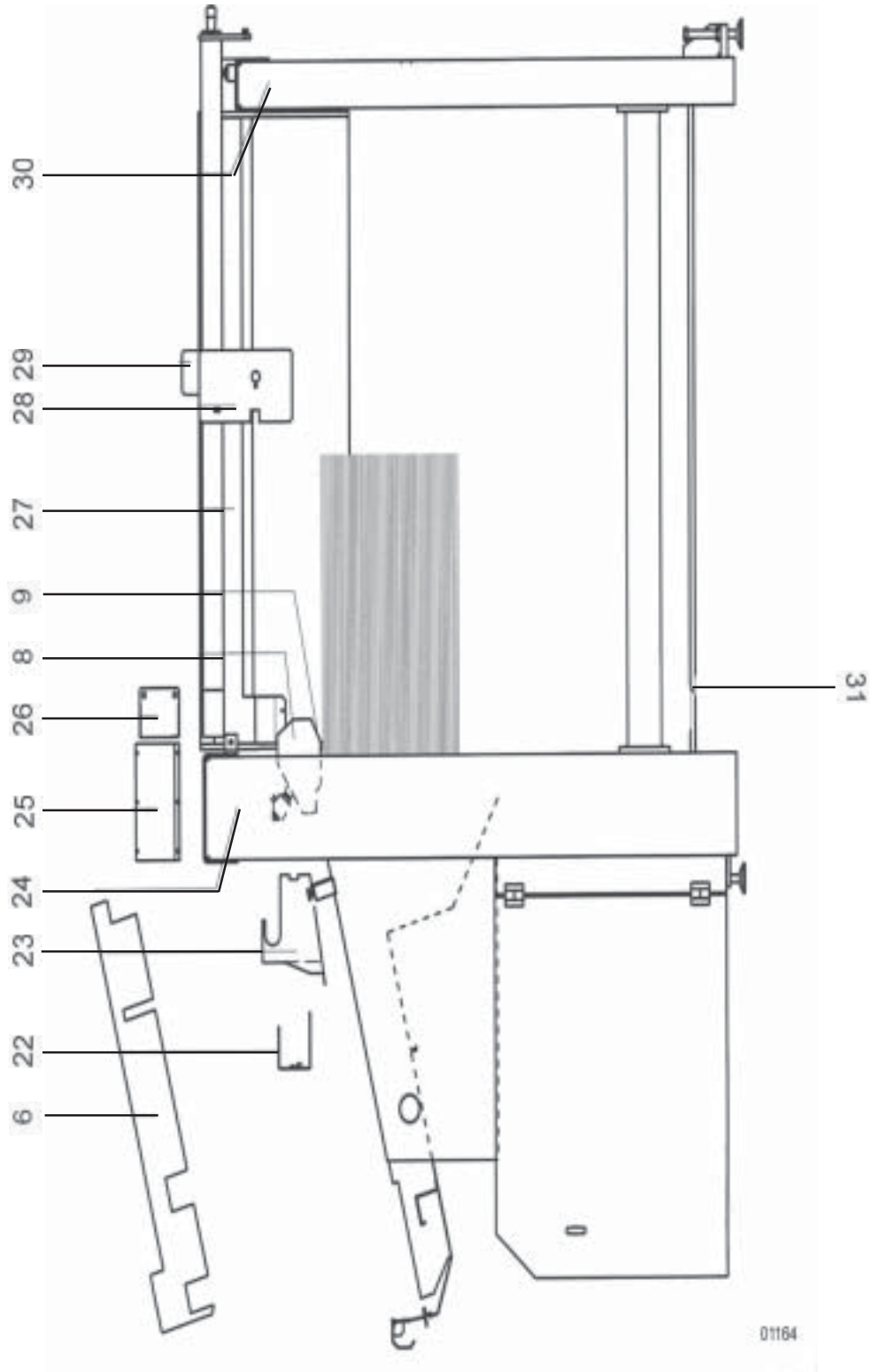

01164

3.0 Transportation / Erection/Installation

This part of the Operating Manual is directed specifically at the competent service personnel and other authorised internal personnel responsible for transportation and installation.

3.1 Transportation



>**DANGER**< The feeder may fall/tip over or slip away! Secure the feeder accordingly!

Unscrew the feeder and move it off the pallet with a forklift at position **1** to its final destination.

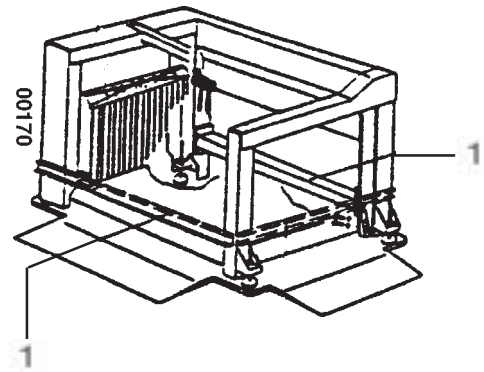

3.1.2 Cleaning



>**ATTENTION**< Clean the feeder with rust preventing agents.

3.2 Erection/Installation

3.2.1 Feeder

Place the feeder onto the levelling screws and plastic feet 1 and move it to the folding unit.

The alignment holes of the register table 2 and the feeder 3 must correspond to each other.

The exact position should be already marked by the company.

Set the exact height through the levelling screws,

adjust 4, 5, and 6 with a <spirit level and screw up without stress.

Continuation

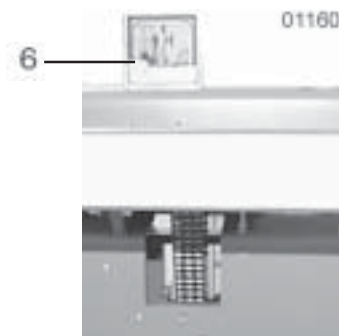
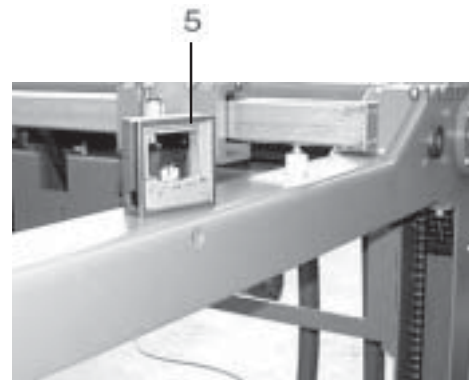
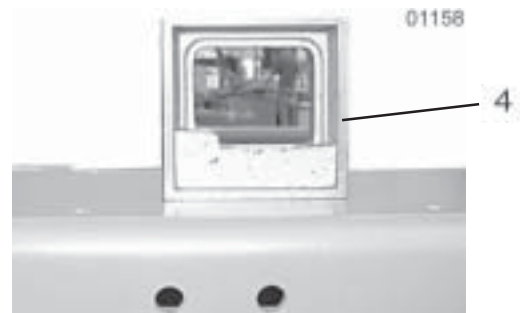
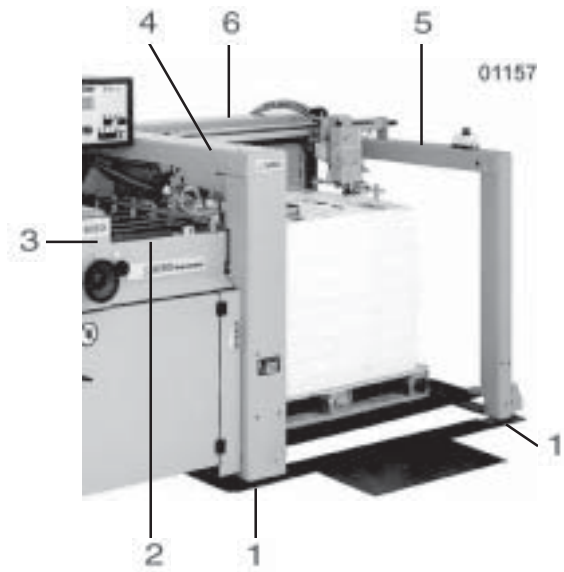

Continuation

Screw up the feeder and the folding unit with the connecting part **7** to the positions **8** and **9** without stress.

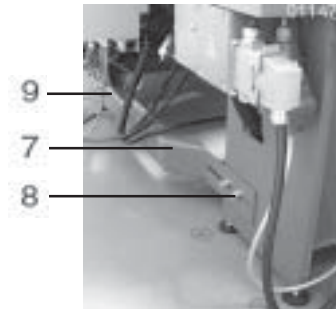

Place the flat belt **10** for the drive of the Vacu-Infeed onto the drive roller and tension it with the tensioning lever **11**.

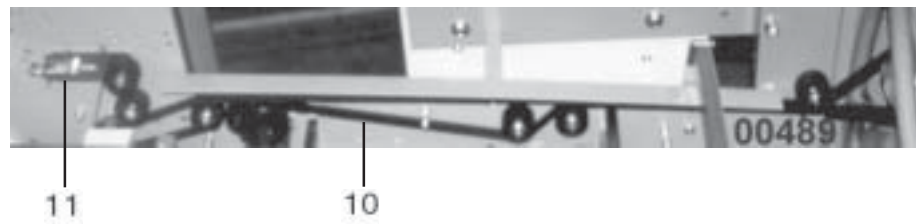

Hang up the lattice **12** at all positions **13**.

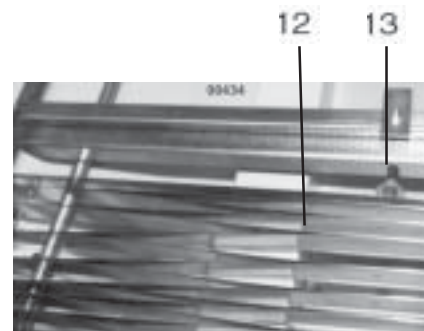

Continuation

Continuation

Remove the transport bars 1.

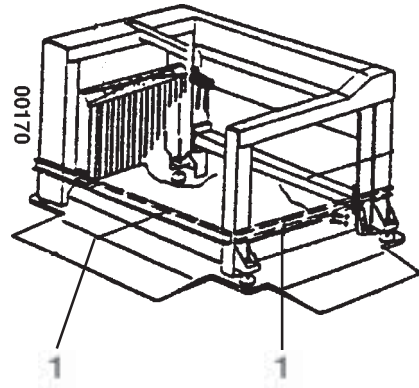

Affix wedge 2 and place the centering wedge 3 beyond the floor. The pile plate 4 should be in its lowest position in the centre of the machine.

Fix the feeder with screwed inserts 5 at positions 6.

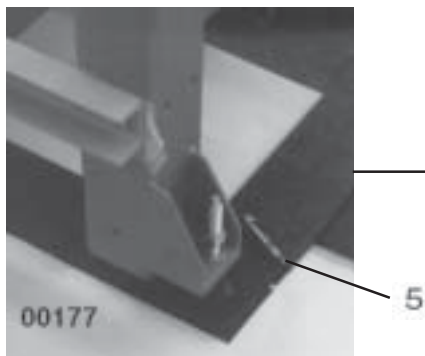
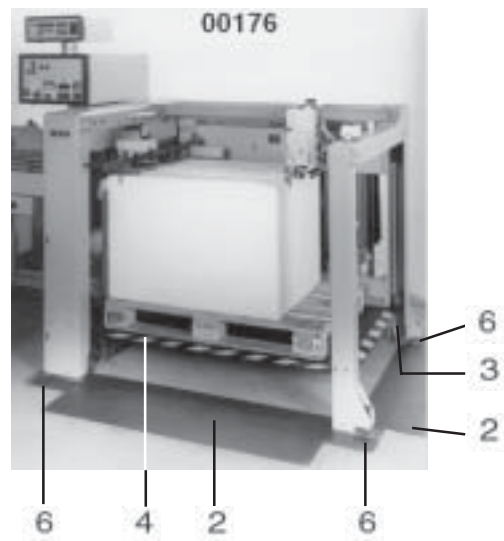

3.2.2 Pressure/Vacuum pump

Put the hoses for vacuum **1** and pressure **2** over the appropriate necks and fasten them with worm drive hose clips. Matching necks and hoses are colour-marked.

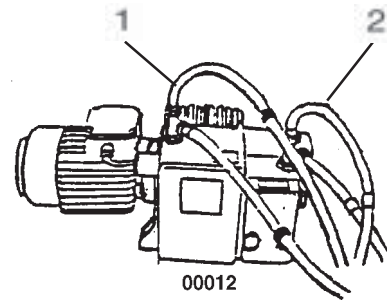

>ATTENTION< Check the clockwise rotation prior to initial operation!
If the motor is turning counter-clockwise it may cause considerable damage to the pressure/vacuum pump!

3.2.3 Guards



>DANGER< Attach all protective hoods delivered with the machine!

Affix the noise guard 1 beneath the register table with 4 screws 2.

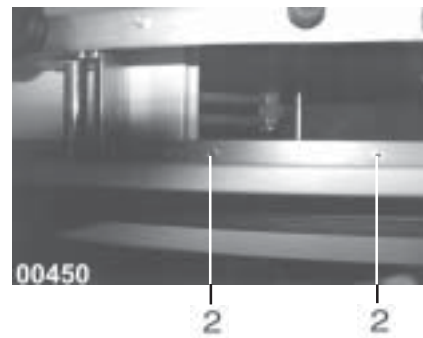
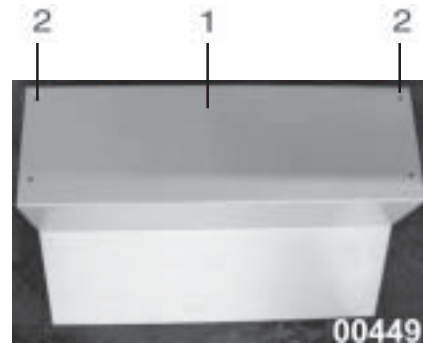

Fit the door containing the tool tray 3.

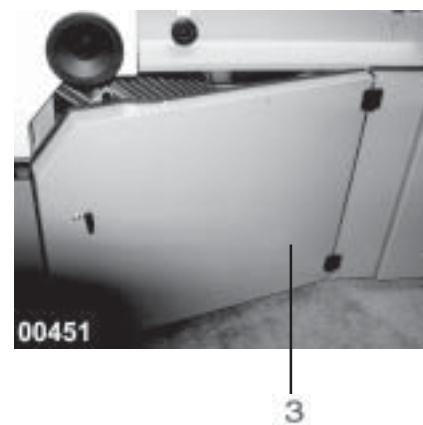

3.3 Electrical connection



>DANGER< These actions should only to be carried out by authorised or skilled personnel!

3.3.1 Installation of main control panel

Fasten the holder/support 1 by means of 2 screws 2 from the internal side.

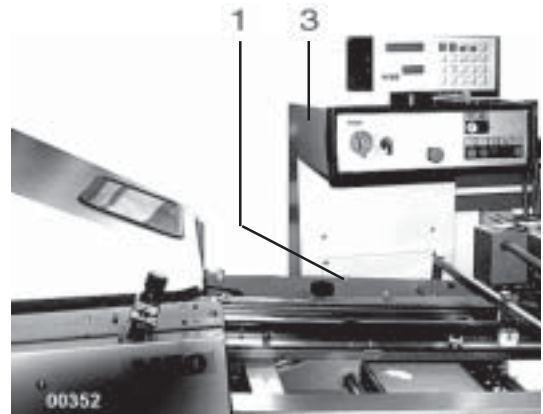

Continuation

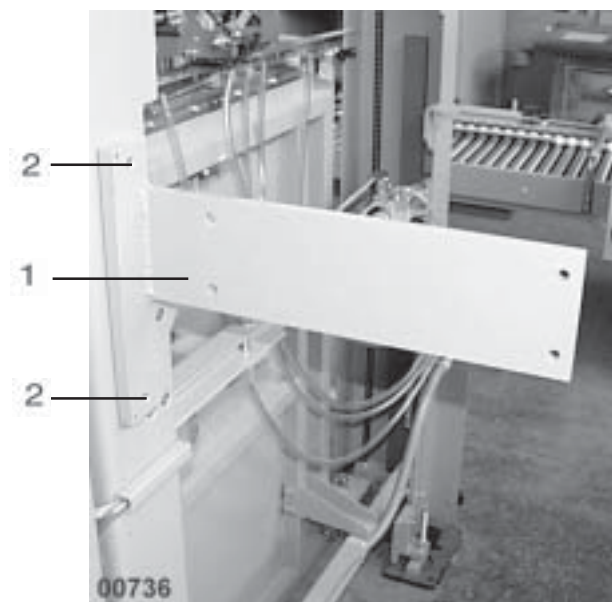
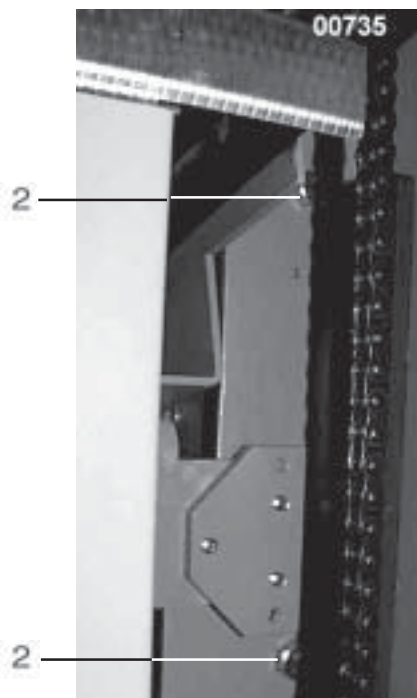

Continuation

Then affix **4** the main control panel **3** onto holder **1**.

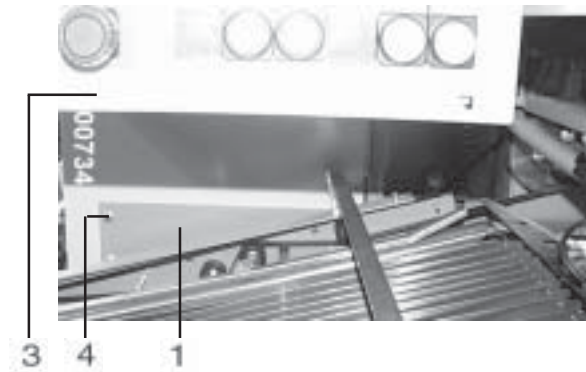

3 to be affixed **6** at bar **5**,
distance piece **7** between **3** and **5**.



Insert the plugs of machine
and feeder into the corresponding
sockets at the control panel.

Matching plugs and sockets
bear the same marking.

Connect the cables of motors directly
with the motor protective switches
at main control panel.

Connect the pressure-/vacuum pump -
cables are numbered.

Please note wiring diagram!

3.3.2 MC - Control

Open the front plate 1 and remove the cover plate at the rear side of the counter 2.

Pull the cable through the opening 3 and insert it through the opening 4 into 2. Place the counter 2 on the adapter 5.

Fasten the screw 6 to such an extent that the counter 2 may still be rotated.

Insert the numbered cable connections 7.

Lock the front plate 1 and affix the cover plate to the rear side of the counter 2.

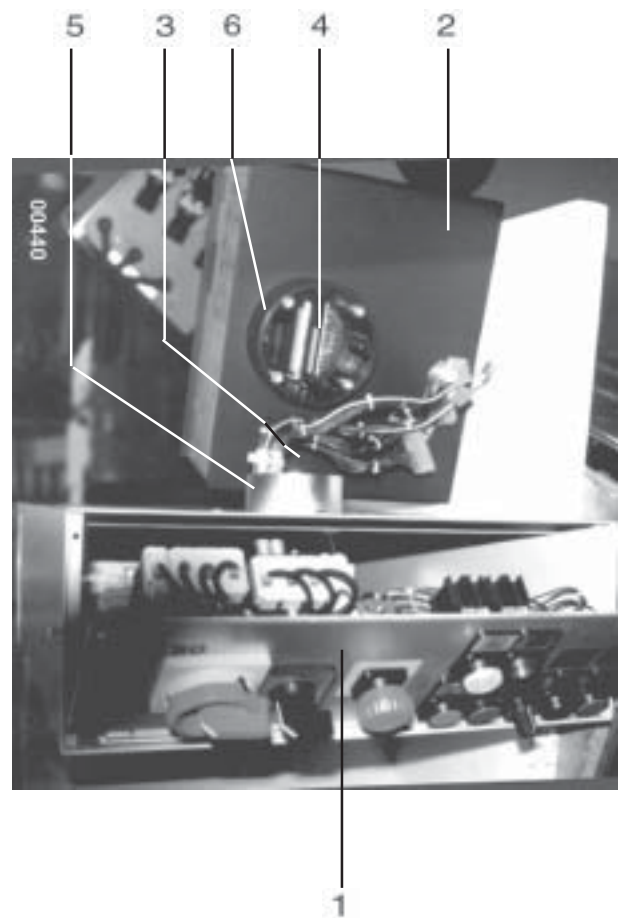
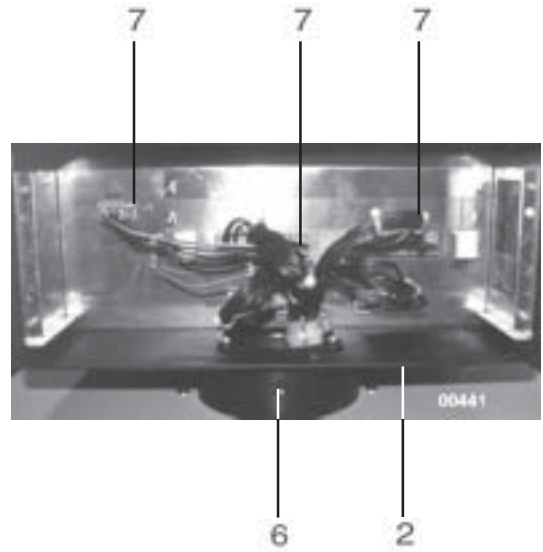

3.3.3 Main Power Connection



>DANGER - MAY BE HAZARDOUS TO YOUR LIFE< These works are only to be carried out by authorized or skilled personnel!



>ATTENTION< Check whether the supply voltage and frequency correspond to the data indicated on the machine label **3**.

Enter the connecting cable from the base of the control panel, connect the wires to the main terminals provided and secure it with protective plates.

Please note wiring diagram!

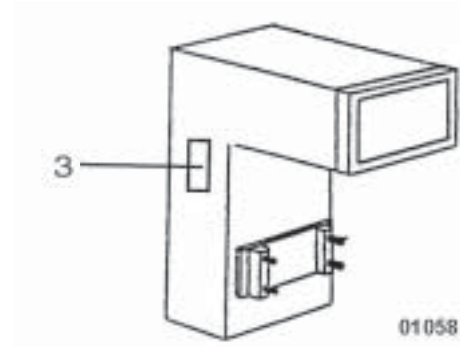

>ATTENTION<
Consider clockwise rotating field!



>ATTENTION< Check the rotating field of the motors! If necessary, alter the terminal strip in the main control panel.

4.0 Service and maintenance

This part is directed towards service personnel or other internally authorised personnel.



>**DANGER**< Unless the feeder is isolated no service or maintenance work should be carried out. Always activate the EMERGENCY STOP button or turn OFF the main switch and secure it with a safety lock.



>**DANGER**< This, as well as the following described work, should be carried out by one person only! Danger of squeezing!!

Procurement of spare parts:



>**ATTENTION**< Only use the spare parts which are supplied or recommended by the manufacturer.

For enquiries and spare parts orders it is necessary to provide the machine and serial number, which may be obtained from the label 1.

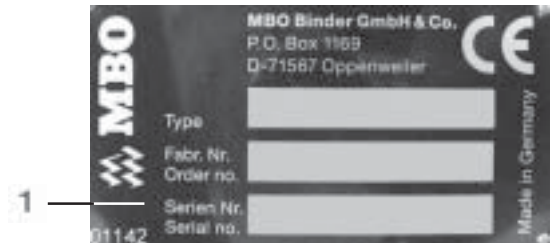

4.1 Exchange and/or tensioning of belts/tapes

4.1.1 Register belt at register table

Loosen the screw **1** and release the tension of the register belt **2** through screw **3**. Unhinge the lattice at **4**. Loosen the screw **5** and remove the rod **6**. Take the register belt off the rollers and thread out at **7**. Insert the new register belt in the opposite sequence.



>ATTENTION<

Centering and adjusting of a new tape:

Loosen the screw **1** and adjust the new tape **2** flush left onto roller **9** through screws **8**. Re-fasten screw **1**.

Thereafter, loosen screw **10** and adjust (left-sided) the new tape **2** through the screws **11**. Make sure that the track of punched holes in the register belt **2** are matching with the bore holes of the vacuum roller **12**. Re-fasten the screw **10**.

Check:
Test with paper strips in the area of the vacuum roller **12** if vacuum is still provided - activate the pressure/vacuum pump!

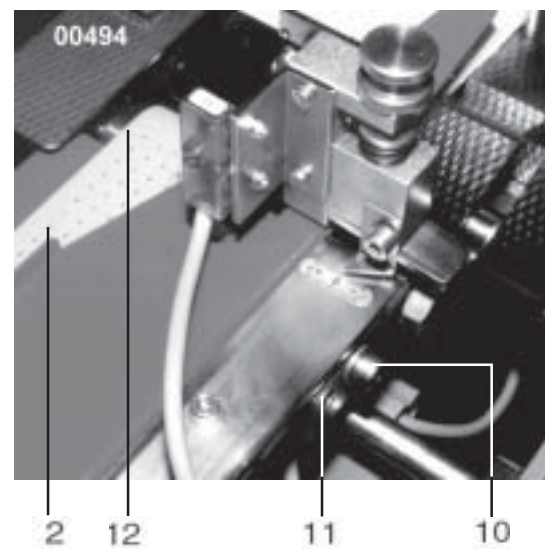
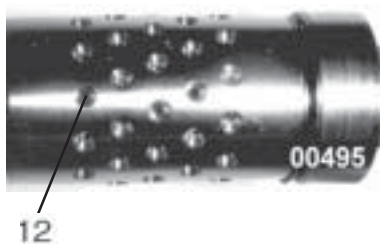
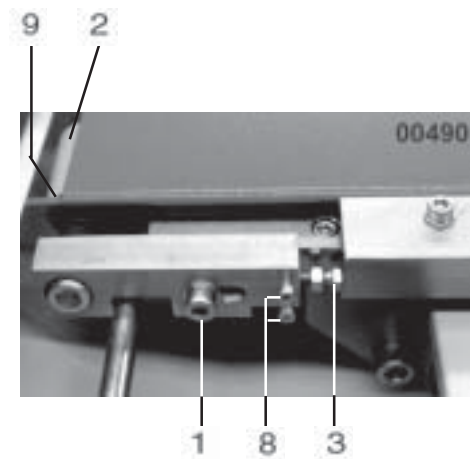
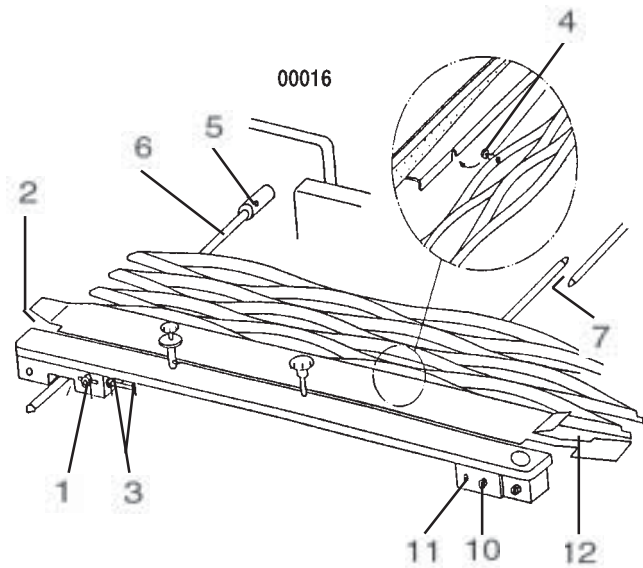

4.1.2 Drive for Vacu-Infeed tape

Tension the drive tape **1** by means of the tensioning lever **2**.

Exchange:

Remove the guard **3**, open **5** the coupling **4**, and re-thread the tape. The installation occurs in the opposite sequence.

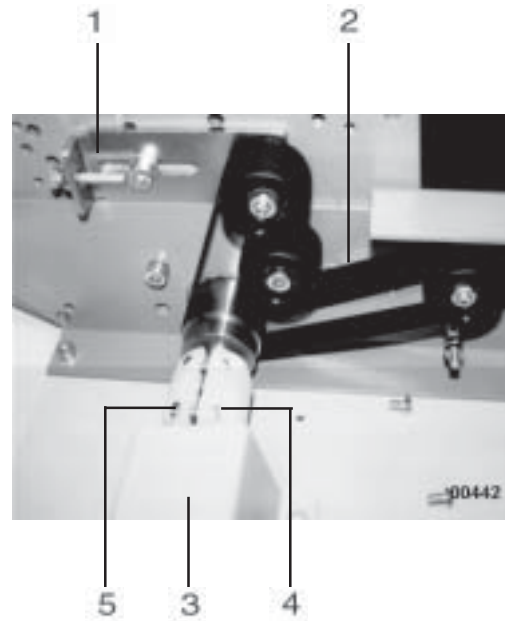

4.1.3 Vacu-Infeed tape

Remove the protective hood **1**,

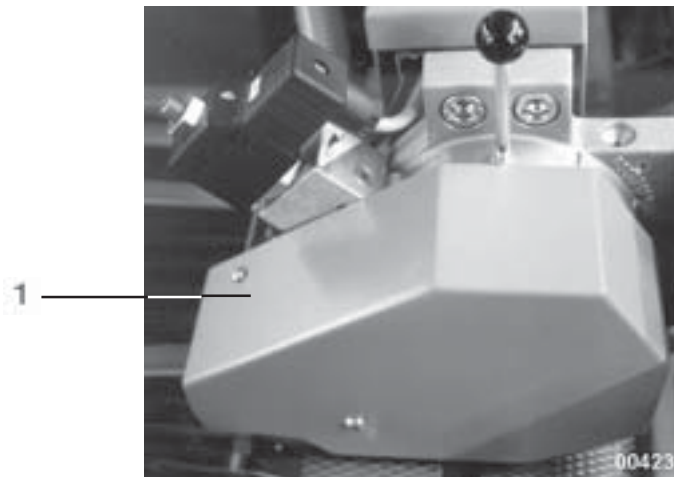

loosen the nut **2** and tension the tape **3**. Insert the screw **4** (make sure it is not too tight!).

Exchange:

Loosen the screw **4**.

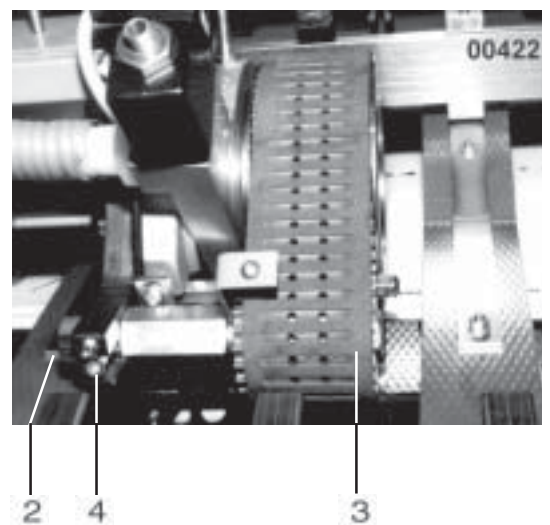

4.1.4 Feeder - tensioning of drive chain

Tensioning of drive chain 1:
Loosen the four screws 2
as well as counter nut 3.
Turn both screws 4 together.



> **ATTENTION** < Do not overtighten.

Refasten screws 2 and counter nuts 3.

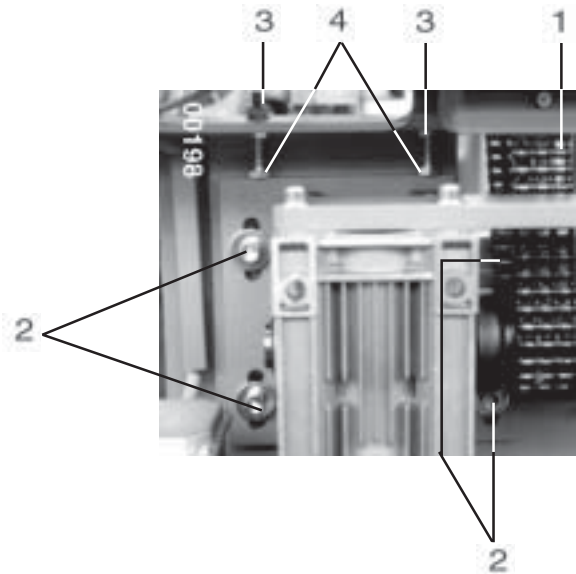

4.1.5 Feeder - final switch (top)

The minimum distance from the pile plate to the suction wheel/Vacubelt has been set by the manufacturer to 155 mm.

Reason: When using EURO pallets, which have the most height (150 mm) of the pallets normally used, it will never occur that the Vacubelt/suction wheel will be damaged by the pallet which is damaged or incomplete in the area of the capacitive switch. If mostly low throw-away pallets are used the pile is not completely processed. In this case you may move the top final position of the pile plate closer to the Vacubelt/suction wheel. However, the manufacturer will not be liable for any damages caused.

Remove the cover 1 at drive side of the feeder 2. The limit switch S 25 3 activates the top final position. Loosen the counter nut 4. When you clockwise turn the screw 5 it will cause a higher final position of the pile plate.



> **ATTENTION** < Adjust sensitively!
One rotary movement of the screw 5 will amount to 10 mm height difference.
Refasten counter-nut 4.

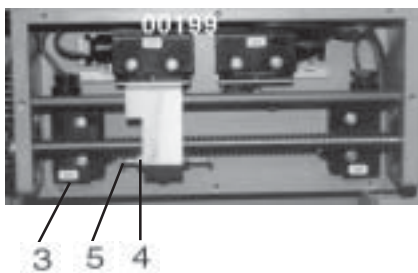
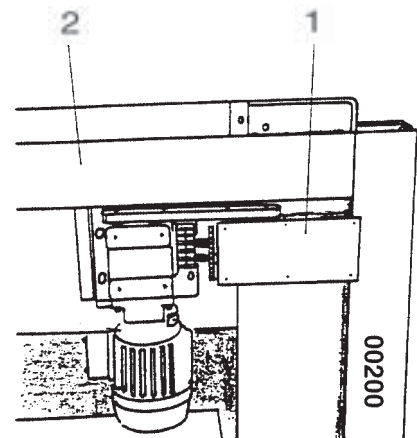

4.2 Lubrication/Cleaning



>NOTICE< Generally, the feeder should be cleaned after each job, particularly moveable parts which have been adjusted due to change of sheet size, etc., because heavy dust may cause a reduction of functions.

4.2.1 Feeder

Check the loose ends **1** of the pile plate chains, clean dust off and provide with a slight touch of oil.

Move the feeder table up to its top position for this work!

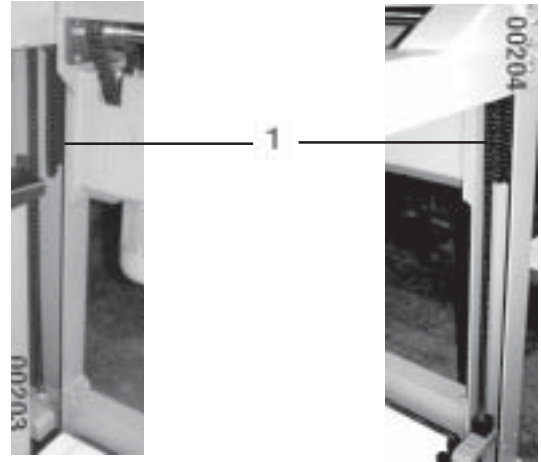

4.2.2 Vaculift

Remove protective hood **1** and spray a slight touch of oil onto all guiding elements and moving parts, on a monthly basis.



>NOTICE< If you spray on too much oil lubricant may drop onto the sheets.

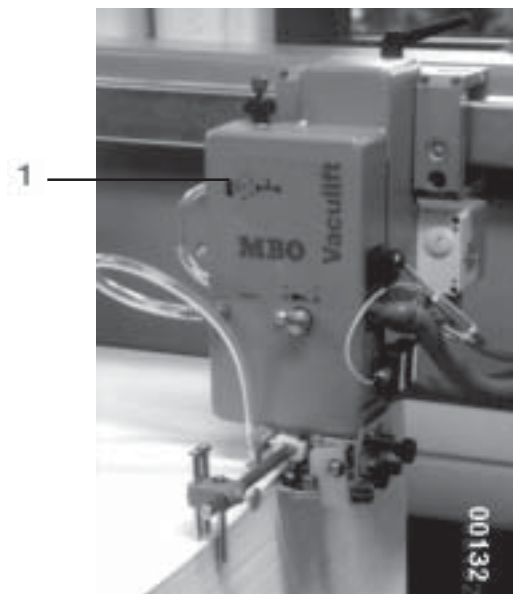

4.2.3 **Axe of pile plate**

Lubricate the axe for lateral setting of the pile plate **1** at the two lubrication nipples **2** left and right once a month.

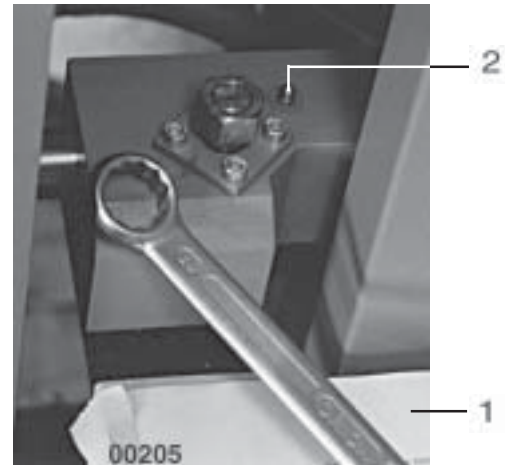

4.2.4 **Register table**

Clean the guide shaft for sheet size adjustment **1** as well as drive shaft **2** off from dust and provide them with a slight touch of oil.

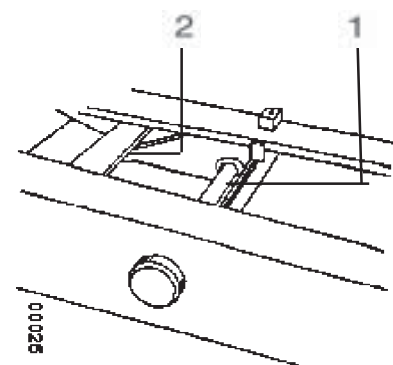

4.2.5 Pressure/Vacuum pump



The cleaning of the pump depends on the use of the folding machine. It may become necessary weekly or at infrequent intervals. Please check the separate Operating Manual of the manufacturer.

>NOTICE< To ensure full efficiency, however, the cartridge at the suction side should be checked and cleaned occasionally. The filter cartridge must be cleaned every 50 hours of operation and be exchanged every 6 months. Dirty or damaged cartridges must be replaced immediately. Do not remove the filter cartridge in any situation, otherwise penetration of foreign substances will damage the pump. Make sure that the pump is turned OFF during any maintenance work.

Remove the caps 1 and 2 as well as the filter cartridges 3, 4 and 5. Clean these cartridges by blowing through from the internal to the external side.

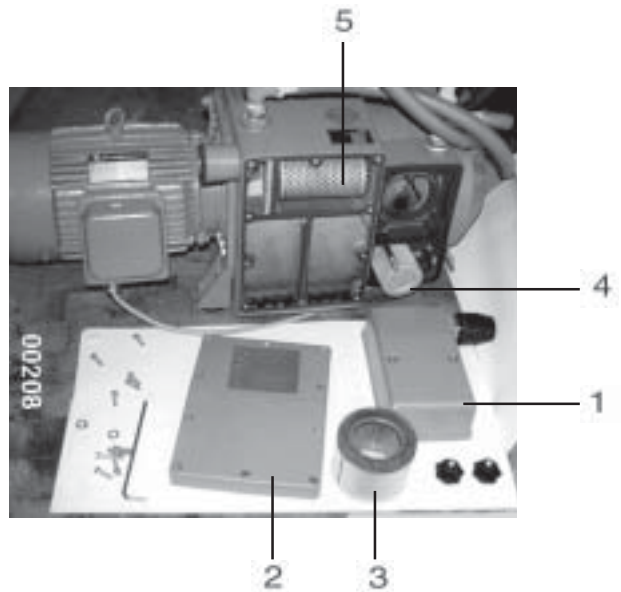

Exchange the filter cartridges every six months.

5.0 Operation of the machine

5.1 Main control panel

- 1 MAIN SWITCH
- 2 ON/OFF switch for AIR PRESSURE PUMP
- 3 Red mushroom button with locking for EMERGENCY STOP
- 4 Button to STOP the machine
- 5 Button to START the machine
- 6 Button for SHEET INFEED during PRODUCTION
- 7 Button for SINGLE SHEET INFEED
- 8 Rotary switch for PILE TABLE UP/DOWN
- 9 Illuminated push button to RELEASE PILE TRANSPORT
- 10 Selector switch for pallet mode/manual piling
- 11 CONTROL LAMP for main drive
- 13 Potentiometer for speed control of folding unit I

- 16 Push button to lower the PILE PLATE; for safety reasons the pile plate will stop approximately 15 cm above the floor. Permanent pushing of the button **16** will cause the pile plate to move down to the floor.
- 17 Batch counter MCC3 with integrated sheet infeed control „MC“. See separate operating manual „MC Control“ for detailed description.

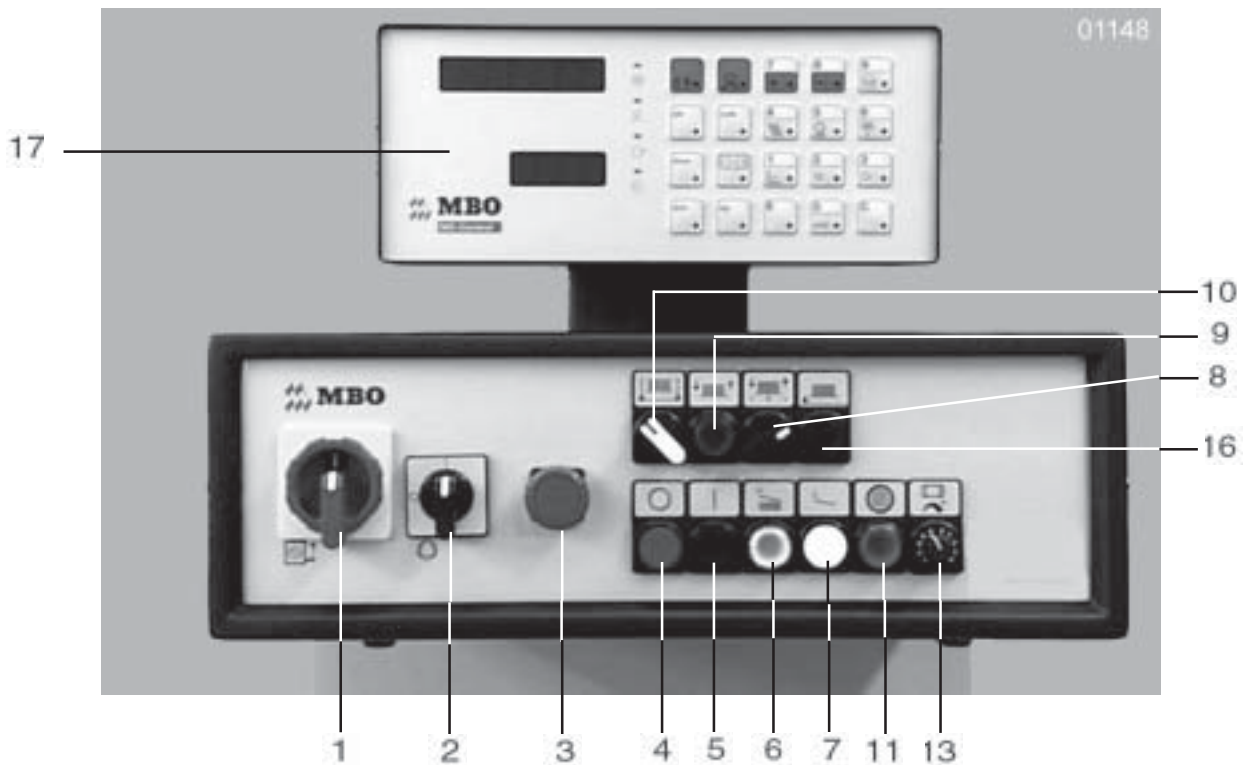

5.2 Feeder

5.2.1 Manual piling

Switch **8** must show the position "DOWN"; push button **9** must be lightening, selector switch **10** must indicate to broken line !

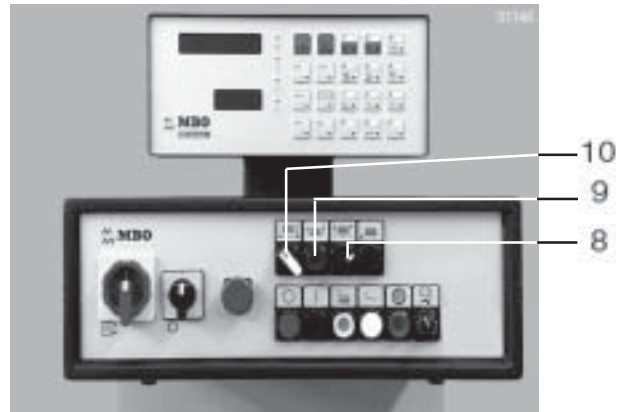

Pile table is moving down until the photocell **1** is uncovered; it remains automatically in an ergonomically favourable position.

Set the pile stop **2** to appropriate size ($\frac{1}{2}$ of sheet width) prior loading the table (scale). Load pile table. Table moves automatically down until photocell **1** is released again. Should, however, the loading is impeded by the position of the „Vaculift“, lift up support bar.

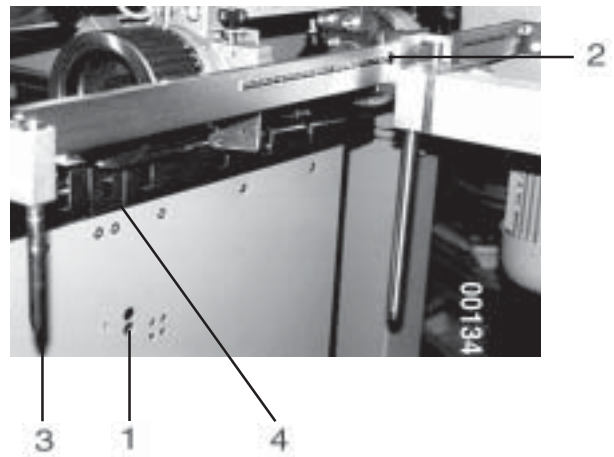

>NOTICE< Sheets which cling or stick together should be aerated sufficiently prior loading!

Place pin **3** to the pile edge. A height adjustable retaining plate **4** avoids an eventual forwarding of the aerated sheets.

Prior you move UP the pile table:

Place the feeder head „Vaculift“ **1** above the pile, position with clamping lever **2**. Rear edge of suckers **3** approximately 2 mm inside, and stop pins **4** at the rear edge of pile.

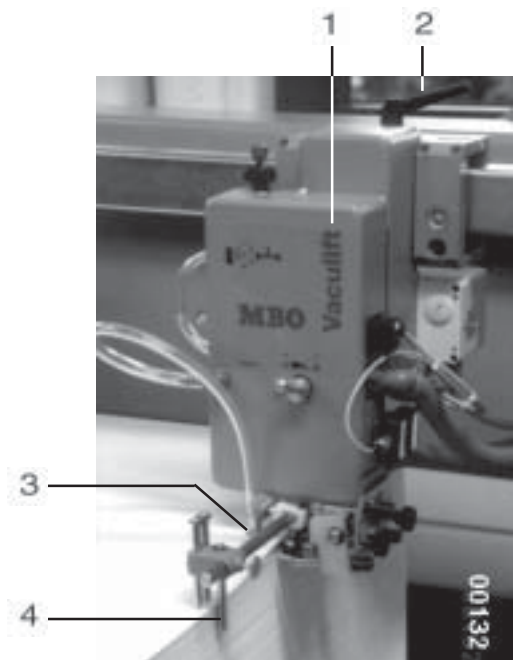

5.2.2 Pallet operation

Switch **8** must show the position "DOWN"; push button **9** must be lightening, selector switch **10** must indicate to continuous line !

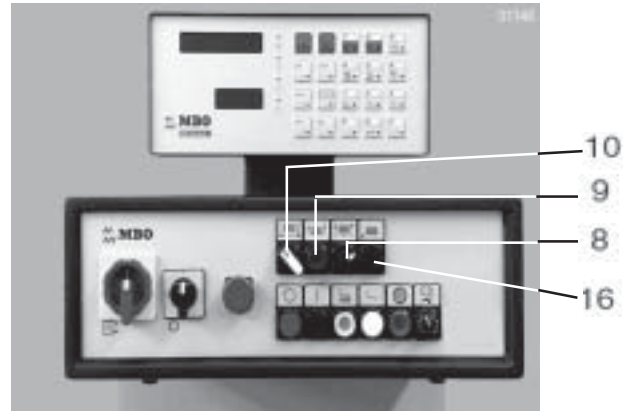

The pile plate **1** moves down and stops at a safety margin of approximately 15 cm above the floor. Push the button **16** continuously for further down movement.



>ATTENTION< Feet of other persons being in the immediate vicinity of the pile plate may be injured!

Enter the pallet from the rear or operators side.

In its lowest position, the pile plate **1** aligns itself by the wedge-shaped angles **2** laterally into the centre position. In the guide rail, these angles **3** push the pile plate **1** approximately 2 cm to the rear, i.e. when the plate moves up the pile is sitting close on the front panel **4**.

Prior you enter the pallet:
Set the pile stop **5** to appropriate size (½ of sheet width).

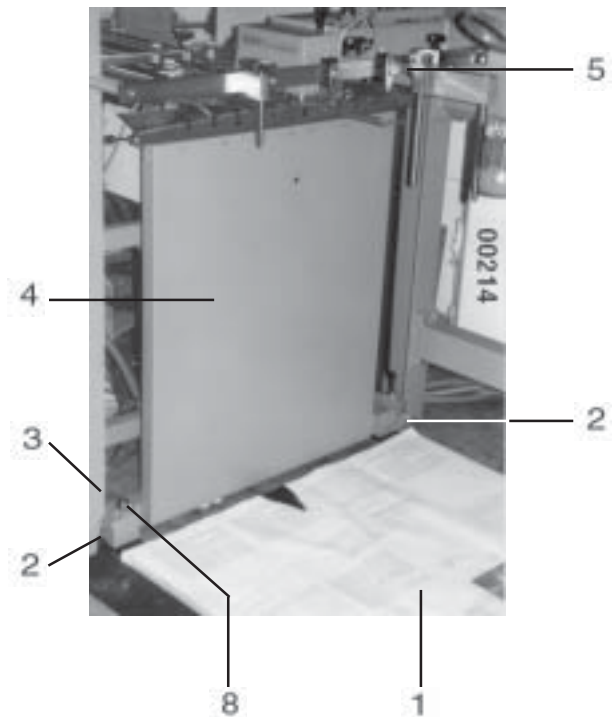

Continuation

The front edge of pile **6** must be align with the front edge of the pallet **7**!

Should the paper size be smaller than the pallet, the pile must be in centre of the pallet.

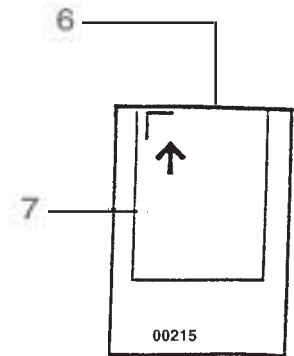

The nut **8** is required for the lateral pile alignment of +/- 20 mm for non-vertical pile **9**.

The centre position is marked red.

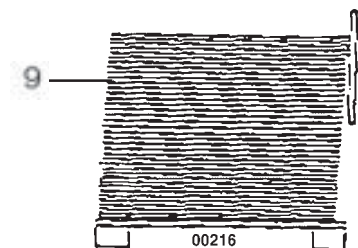
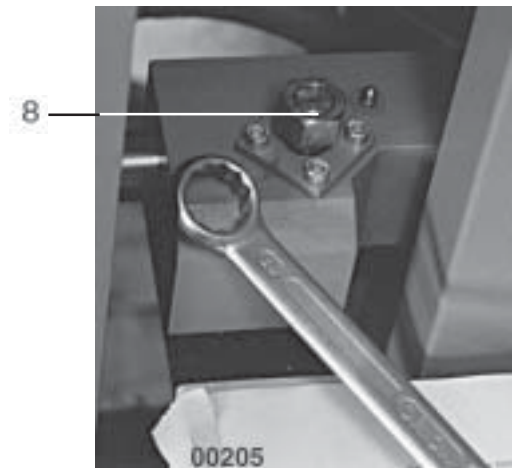

5.2.3 Height control of pile and „Vaculift“

The pile UP movement is stopped by the proximity switch **1**.
The distance between the suction wheel and the pile is approximately 7-8 mm; this basic setting has been made by the manufacturer.
Alterations, depending on the sheet pile, through knurled screw **2**.



>ATTENTION < Make sure that proximity switch **1** is not covered!

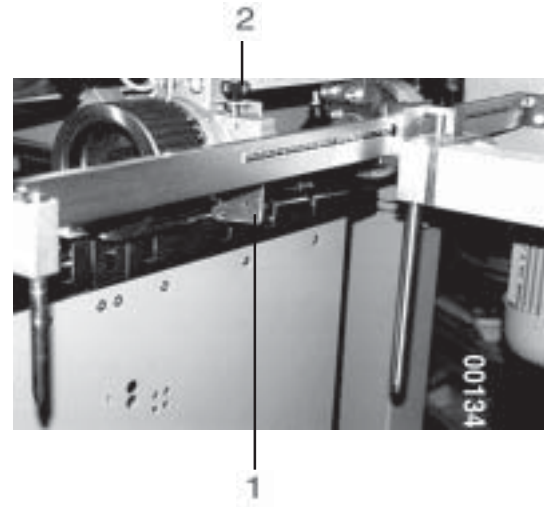

After the pile STOP:

The „Vaculift“ is automatically moving onto the rear edge of pile. The pressure foot **3** stops the down movement shortly after reaching the top edge of pile.

Pile DOWN:

The „Vaculift“ always moves time-delayed into its top position.

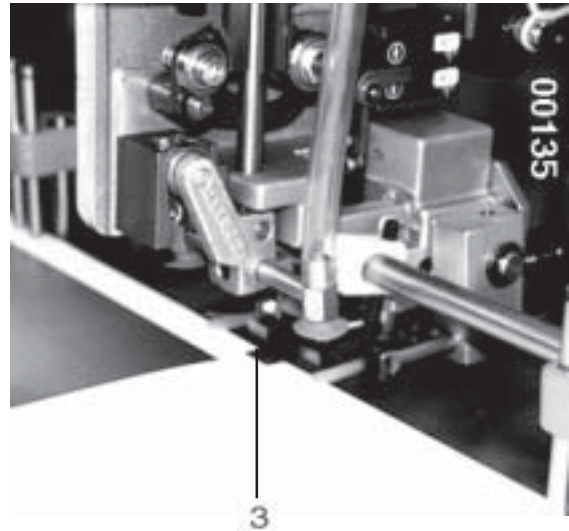

5.2.4 Feeder head „Vaculift“

Basic position of „Vaculift“:
The sucker **1** approximately 2-5 mm distance from the rear edge of pile and 2 mm above the pile.
Adjustments through knurled screw **2**; measurements can be read-off at scale **3**.
In case you process voluminous papers: Cant **4** the sucker **1** slightly (through screw **5**). This will not suck-on the sheet entirely on its surface.

Stop holders **6** should fix small sheets sizes laterally and to the rear.
Large sheet sizes:
Move the stop holders **6** as far as possible off the „Vaculift“.

Double sheets are stripped off by the brushes **7**; they should reach approx. 4 mm into the pile, distance approx. 1 mm.

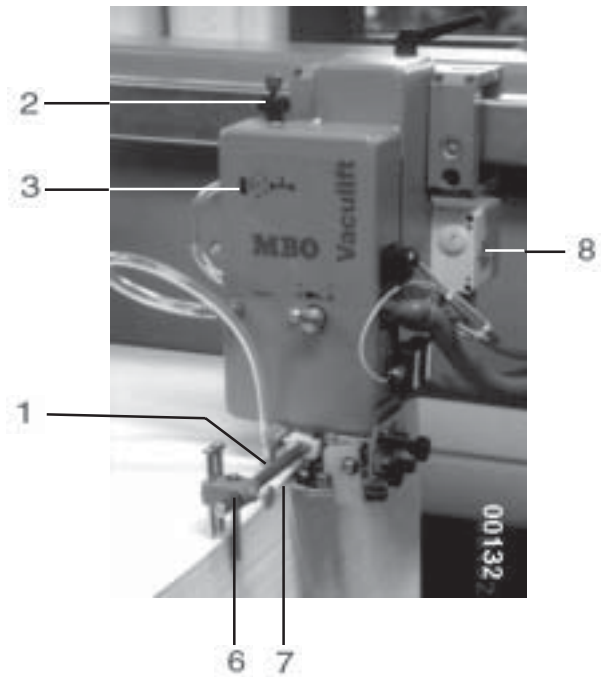

>NOTICE< Depending on the type of paper and power of air blast it may become necessary to slightly push the brushes **7** onto the pile.

Selector switch **8** for **ON/OFF**.

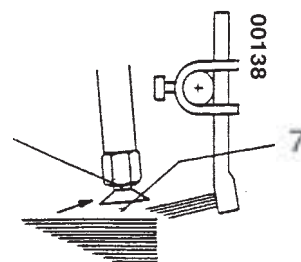
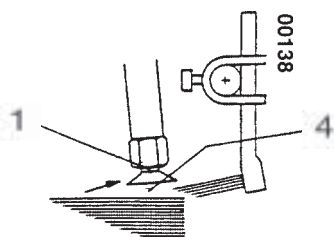
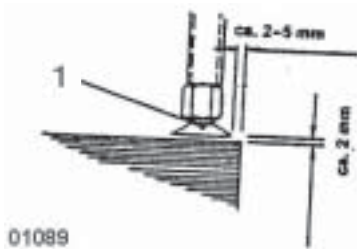
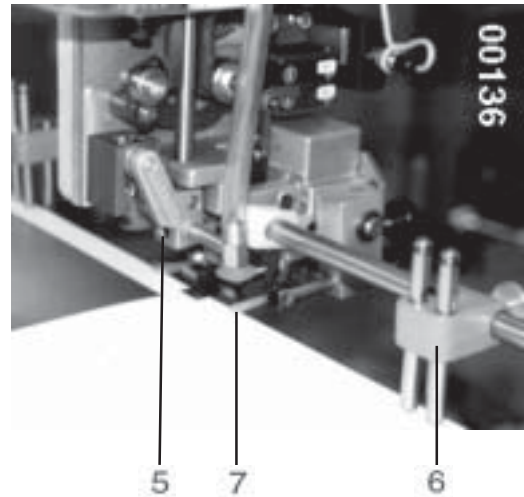

5.2.5 Air support

Air blast and suction air of the feeder is provided by a pressure/vacuum pump. ON/OFF position occurs through switch **2** at main control panel. Button **6** SHEET INFEED: suckers move down and lift the first sheet of pile.

How to regulate the air blast of the nozzles **1** through the adjustment knob **2**: Increase the power of air blast slowly until the sheet is slightly fluttering and touching at the suction wheel. Change the air blast direction at large or oblong sizes: loosen the screw **3**.

Pre-blowers **4**: height adjustment through knurled screws **5**. Regulate the air blast through the adjustment knobs **6** so that the top sheets of the pile are ventilated in a „mushroom-“ shape.

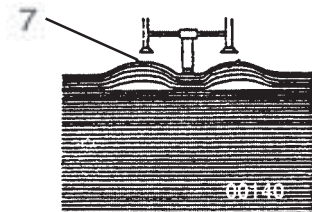

For various types of papers adjust the power of suction of both suckers through the knurled screw **8**.

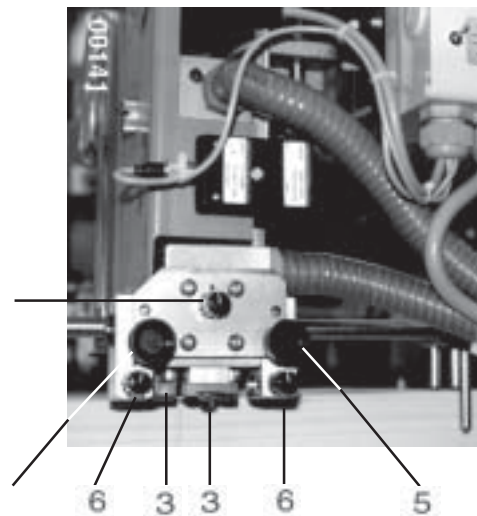
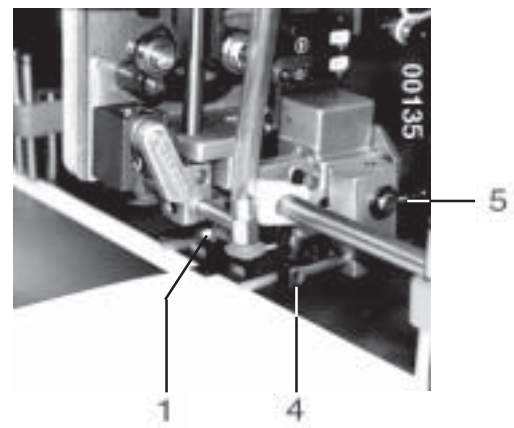
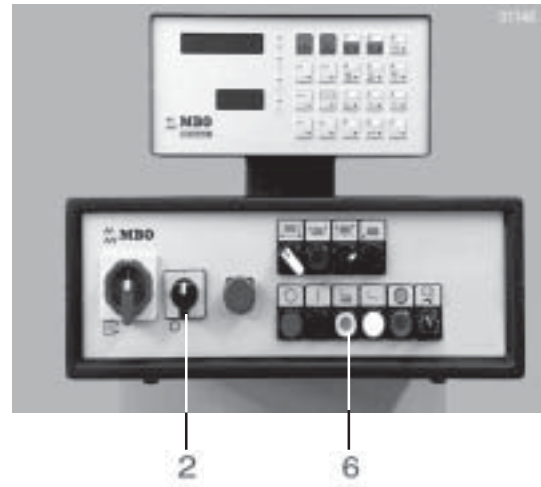
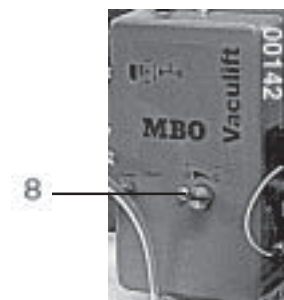

5.2.6 Front air nozzles

These nozzles enable you to separate difficult papers much better.

The positions of the centre nozzles **2** and **3** are fixed. For various paper sizes you can shift the left **1** and the right **4** nozzle on the rod **5**.

Make sure that only the upper 10-15 sheets are ventilated.

How to change the blowing direction:
Swivel rod **5** through lever **6**.
If necessary, the nozzles may also be swivelled individually.

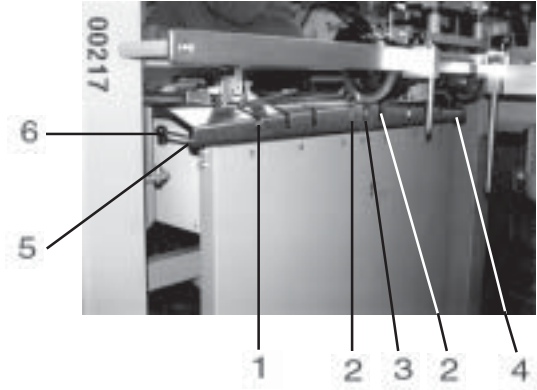

Valves:

Regulate the quantity of air through valves **1** thru **4**.

Nozzles and valves belong to each other are marked with the same numbers.

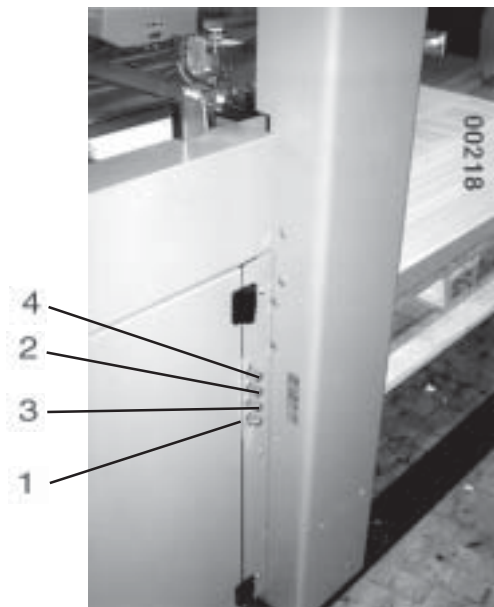

5.2.7 Small sheet-size device

This device is only used for sheets of less than 17 cm of length:
Turn off „Vaculift“ through toggle switch **1**, move it to the rear or lift the support bar **2**.

Affix the small sheet-size device **3** with two screws **4** onto the tie-bar **5**.
The pins **6** must touch the end of pile.
The holding pin **7** must rest on the end of pile thereby slightly holding the sheets.
Lock through knurled grip **8**.

Ventilation only through frontal air support (see item 5.2.6).



>NOTICE< The nozzles should only ventilate the upper sheets (approximately 10-15).

The faster the production the more sheets must be ventilated. Loading and height control is described under items 5.2.1 and 5.2.2.

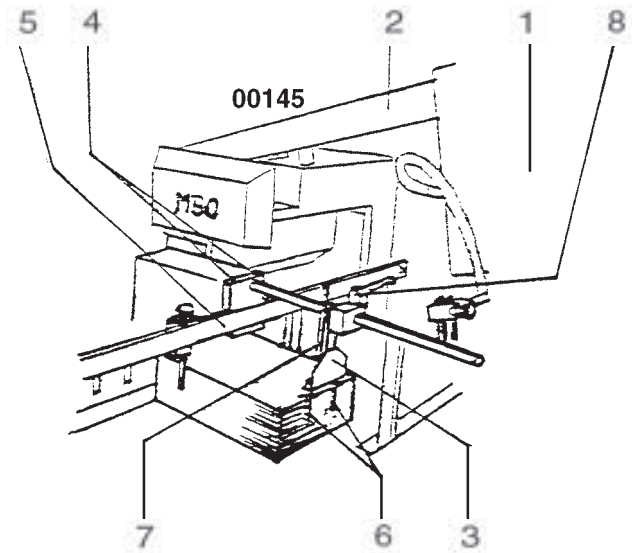

5.2.8 Vacu-Infeed

The Vacu-Infeed **1** carries the sheets onto the register table **2**.

The power of vacuum for various types of paper can be adjusted through the red screw **3**, use the scale +/-

Depending on the sheets' tendency for rolling, the point of suction can be set forward or backward through the lever **4**.

The red markings **5** indicate the position.

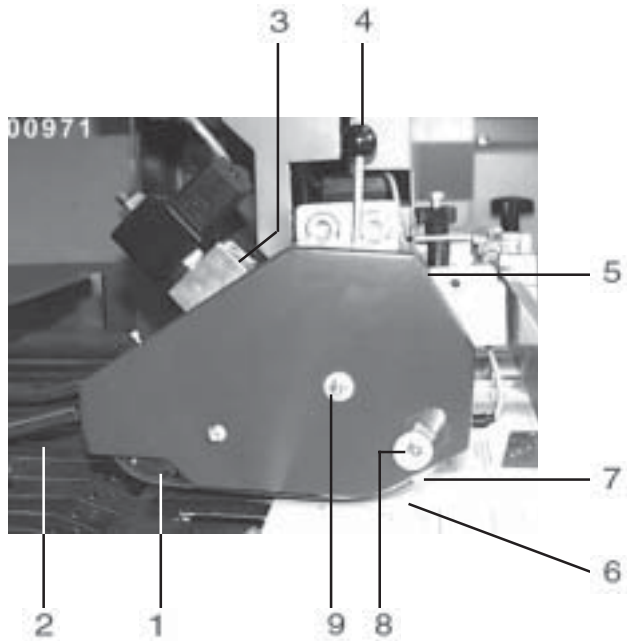

>**DANGER**< The distance **6** between the piles' surface and the protective angle **7** must be set as small as possible - not to exceed 8 mm -.

Refasten the nuts **8** and **9** after the adjustments.

5.3 Register table

5.3.1 Vacu-Alignment

The Vacutable 1 has a separate vacuum pump **3**. ON/OFF switching occurs through the switch **2**.

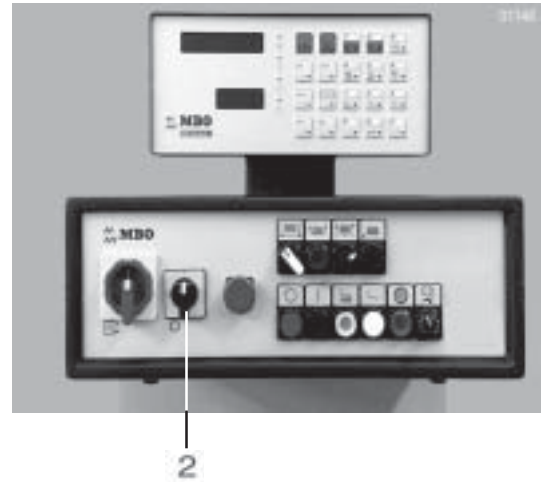

Set the sidelay **4** through the knurled grip **5** to $\frac{1}{2}$ of the sheet width at the mm scale **6**. Fine adjustment is made through the knurled grip **7**.

Angle to the fold rollers: loosen the knurled screw **8**. Settings can be made at the eccentric **9** and the values read at the mm scale **10 +/-**.

Set the guide plate with the rail **11** above it to such an extent that the sheet edge runs between it.

The quantity of smoother bars **12** above the lattice fence **13** is dependent on the sheet width.

Heavy or thick paper requires more vacuum than light or thin paper.

The setting occurs at the grip **14**, scale +/-.

For safe transfer at infeed, heavy or oblong sheets require more vacuum. Thin sheets require less vacuum at the parallel section; setting occurs through the lever **15**, scale +/-.

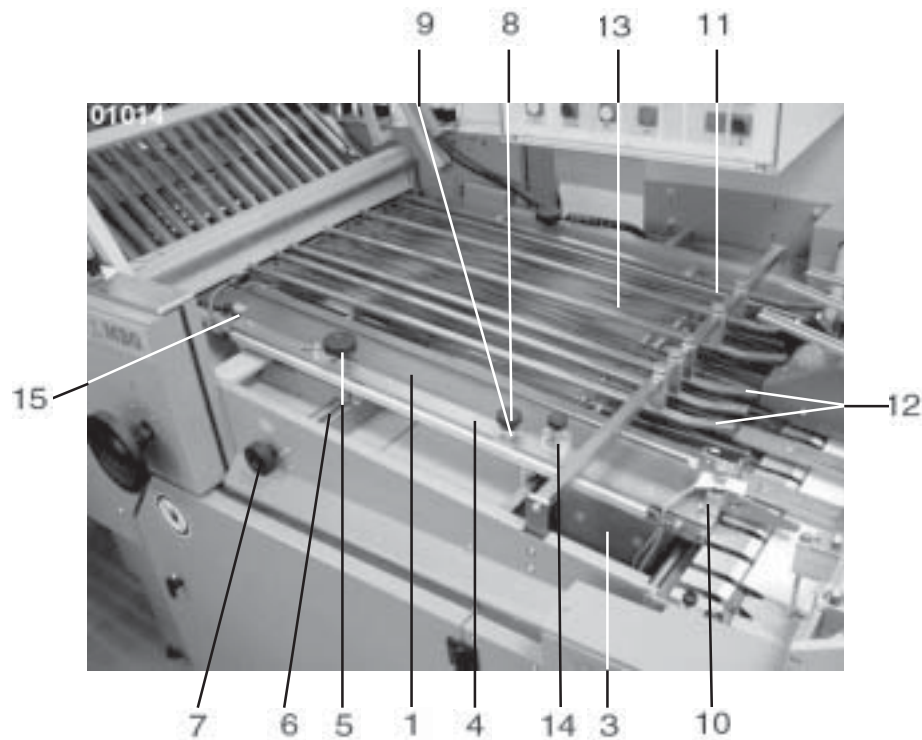

5.3.2 Double sheet control

Press the lever 1 and insert a paper strip (which you are processing) into the gap 2 between the bolt 3 and the knurled screw 4.

Insert a double paper strip under the segment 5 while the machine is running. Turn the knurled screw 4 until the segment 5 has switched, and counter it with the knurled nut 6 after the adjustment of the double sheet control has been completed.

If you check with a single paper strip the machine must continue to run. Re-adjust, if necessary!

Please note that the double sheet control stops the sheet infeed at first. The machine will stop if no sheets are in the machine!

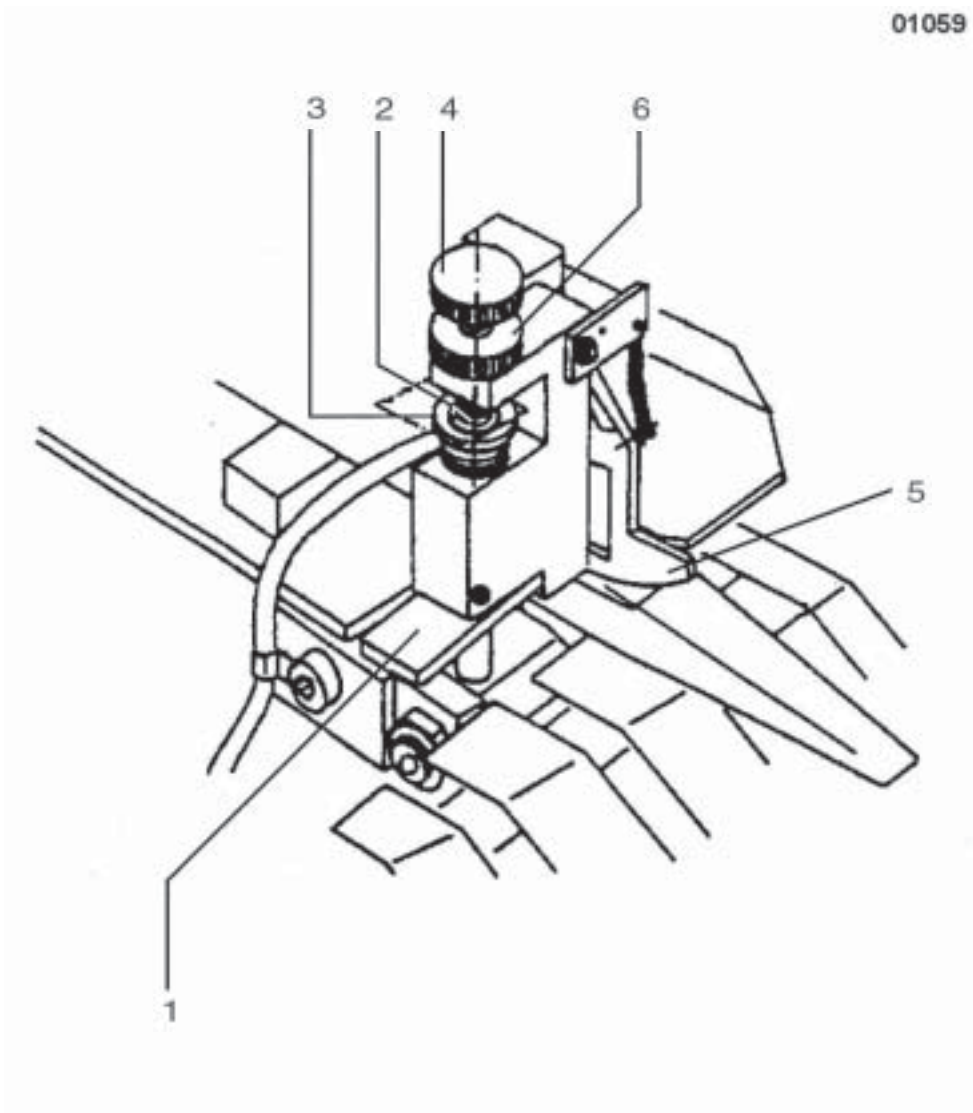

5.4 Sheet infeed control

5.4.1 Automatic „learning“ of suction length and sheet gap

Start the machine **5** and turn on the pump **2**.

Keep the button SUCTION LENGTH **18** pushed and activate the SINGLE SHEET **7** button.

A „learning“ sheet is entered with a basic suction length. It is measured by a photocell whereby the required sheet length is automatically determined.

If necessary, you may increase or decrease the suction length by pushing the buttons **18** and **19 (+)** or **18** and **20 (-)** simultaneously.

Adjust the machine.
Set photocell **23** above the sheet exit.

Calibration of sheet monitoring:
Keep the button SHEET GAP **21** pushed and activate the SINGLE SHEET **7** button. All photocells are calibrated by one „learning“ sheet. The (minimum) sheet gap is determined at 2 cm.

If necessary, increase the sheet gap as follows: push the buttons SHEET GAP **21** and **19 (+)**.

Sheet gaps of more than 2 cm may be reduced through the buttons **21** and **20 (-)**.

Please also follow the attached Operating Manual „MC“.

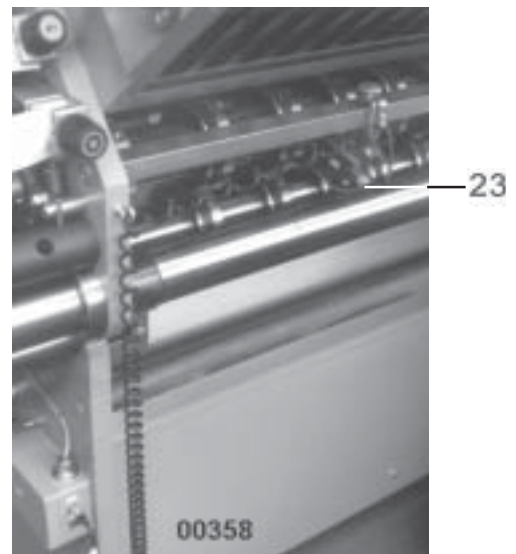
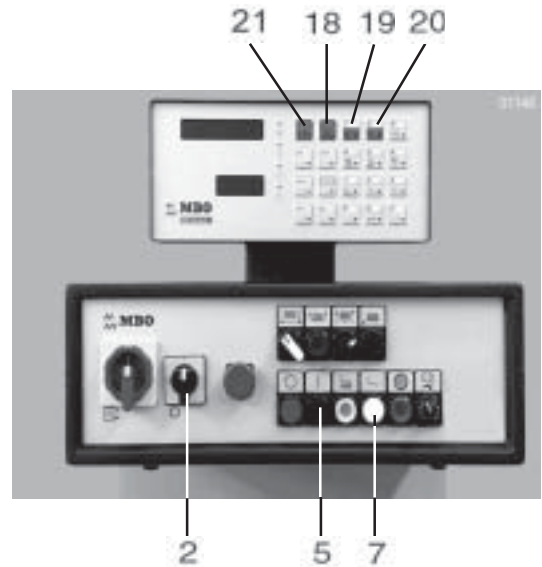

5.4.2 Photocells (Standard)

- 1 controls the sheet infeed at suction wheel/Vacu-Infeed and counts the infeed sheets.
- 2 controls the infeed of parallel section and calculates the sheet or suction length.
- 3 controls the exit of the parallel section and counts the sheets at exit.



>NOTICE< The machine will stop if one sheet fails to pass one of these photocells at the exact calculated time or is passing this photocell longer than calculated.

The MC-Control will display an **ERROR REPORT 22**. It will show the position of the error - see also Operating Manual attached separately.

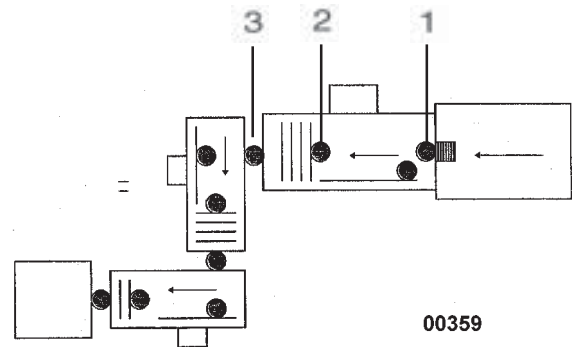

Calibration of photocells:

Adjust the machine completely (folding length, foldrollers, etc.) and push buttons **7** and **21** simultaneously.

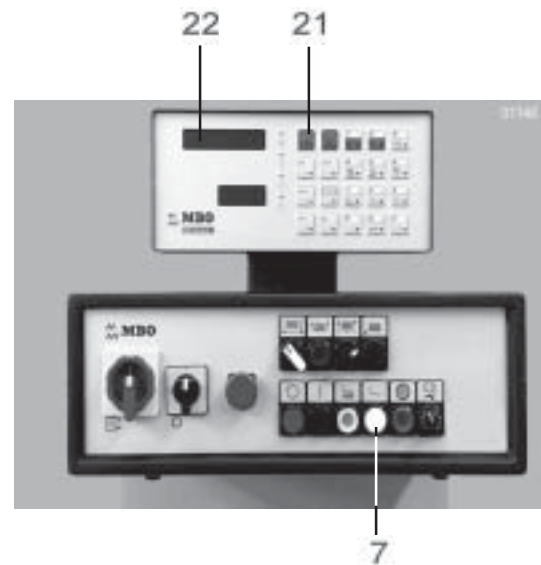

A “learning sheet” is passing the machine. The photocells detect lengths and times of passage. This will automatically program sheet control and sheet monitoring.

5.4.3 Photocells in folding units II and III (option)

In addition to the standard design (5.4.2) the following items are available:

- 4 Photocell controls the infeed at sidelay of folding unit II
- 5 Photocell controls the infeed at folding unit II
- 6 Photocell controls the exit at folding unit II
- 7 Photocell controls the infeed at sidelay of folding unit III
- 8 Photocell controls the infeed at folding unit III
- 9 Photocell controls the exit of folding unit III and the transition to a subsequent unit



>NOTICE< The machine will stop if one sheet fails to pass one of these photocells at the exact calculated time or is passing this photocell longer than calculated.

The MC-Control will display an **ERROR REPORT 22**. It will show the position of the error - see also Operating Manual attached separately.

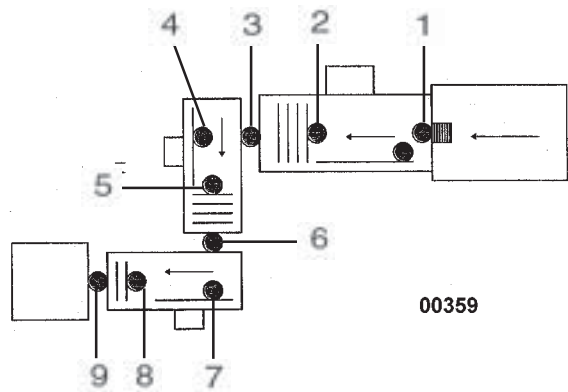

Calibration of photocells:

See the attached special Operating Manual

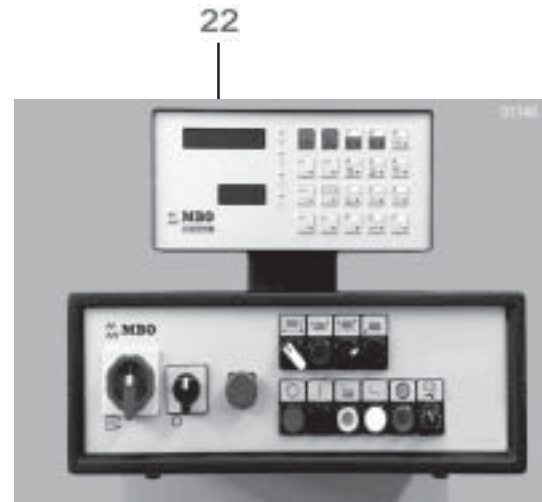

6.0 Options

6.1 Batch counter

The counting functions of the standard batch counter MCC 3 are integrated into the „MC Control“ and are described as „MC Control“ in the attached Operating Manual. Should, however, another counter have been installed by the manufacturer, its Operating Manual is also attached separately.

6.2 Other options

If this feeder does not contain the options, separate manuals are attached with.

6.3 Final remarks

You have now reached the end of this Operating Manual. We hope that you have understood everything. If so, then our efforts to prepare this Manual have been worthwhile. Of course, we accept comments and wish to thank you for any suggestions you may have to improve it. Even we are not perfect! We wish you every success with this machine. However, should you have any problems with its operation, please do not hesitate to contact our technicians or supervisors who will be able to assist you.



Änderungen vorbehalten
Alterations reserved
sous reserve de modifications

Binder & CO.
Postfach 1169
D - 71567 Oppenweiler

Telefon 07191 / 46-0
Telefax 07191 / 4634
<http://www.mbo-folder.com>

Stand 04/2003 H/N