

Schuppenstrommodul Shingle stream module

Ersatzteilliste
Spare part list
Liste des pièces de rechange



 A row of seven stylized blue arrows pointing right, identical to the one in the MBO logo. **SSD 770**

Für künftige Verwendung aufbewahren!
Keep for future use!
A ranger en vue d'une réutilisation future!

Art der Maschine: Type of machine: Type de machine:	Schuppenstrommodul Shingle stream module	
Ausführung: Model: Version:	SSD 770	
Art des Dokumentes: Typ of document: Nature du document:	Ersatzteilliste Spare part list Liste des pièces de rechange	
Hersteller: Manufacturer: Le fabricant:	MBO Maschinenbau Oppenweiler Binder GmbH & Co. KG Postfach 1169 71567 Oppenweiler DEUTSCHLAND Tel.: +49 7191 46 0 Fax: +49 7191 46 34 http://www.mbo-folder.com info@mbo-folder.com	
Ersatzteil - Bestellung: Spare parts order: Commande de pièces détachées:	Service Ersatzteile/Spare parts service MBO Binder Spółka z o.o. ul. Brukowa 6/8 lok.47 91-341 Lodz POLEN / POLAND NIP 947-194-86-60 REG. 100432564 Tel. + 48 42 613 15 50 Fax + 48 42 613 15 66 e-mail: j.andrzejczak@mbopolska.pl	
Dateiname: File name: Nom de fichier:	ETL_SSD770_pl_en_de_V1.0	
Version:	V1.0	Hauptstückliste: Main parts list: Liste de pièces:
Stand: Date: Mise à jour:	21.12.2012	Komissions-Nr.: Commission-No.: N° de commission:
Sprache: Language: Langue:	de en fr	Techn. Redakteur: Artur Krol Technical editor: Rédacteur technique:

Änderungen vorbehalten!
Alterations reserved!
Sous réserve de modifications!

Kundendienstinformation

Halten Sie bei Ersatzteil-Bestellungen unbedingt die nachfolgenden Angaben bereit. Dies gewährleistet eine schnelle und fehlerfreie Auftragsbearbeitung.

<ul style="list-style-type: none">• Kommissionsnummer, Fabrikationsnummer• Maschinentyp	Sie finden diese Angaben am Typenschild Ihrer Maschine.
<ul style="list-style-type: none">• Teilebezeichnung• Teilenummer• Dokumenten-Nummer	Sie entnehmen diese Informationen der Ersatzteilliste Ihrer Maschine.

Die ausführlichen Informationen dazu finden Sie direkt zu Beginn der Ersatzteilliste.

Service information

In case of spare part orders, it is necessary to keep the following information ready.

This guarantees a quick and error-free order processing.

<ul style="list-style-type: none">• Commission number, Fabrication number• Machine type	You will find these information on the type plate of your machine.
<ul style="list-style-type: none">• Part designation• Part number• Document number	You will find these information in the spare part list of your machine.

You will find the detailed information at the beginning of this spare part list.

Information service après-vente

En cas de commandes concernant des pièces de rechange, veuillez tenir les indications suivantes à votre disposition. Ainsi, un traitement rapide et sans fautes de la commande peut être garanti.

<ul style="list-style-type: none">• Numéro de commission, Numéro de fabrication• Type de la machine	Vous trouvez cetttes indications à la plaque signalétique de votre machine.
<ul style="list-style-type: none">• Désignation d'article• Numéro d'article• Numéro de document	Veillez prendre cetttes informations de la liste de pièces de rechange de votre machine.

Vous trouvez les informations détaillées au début de votre fichier de pièces de rechange.

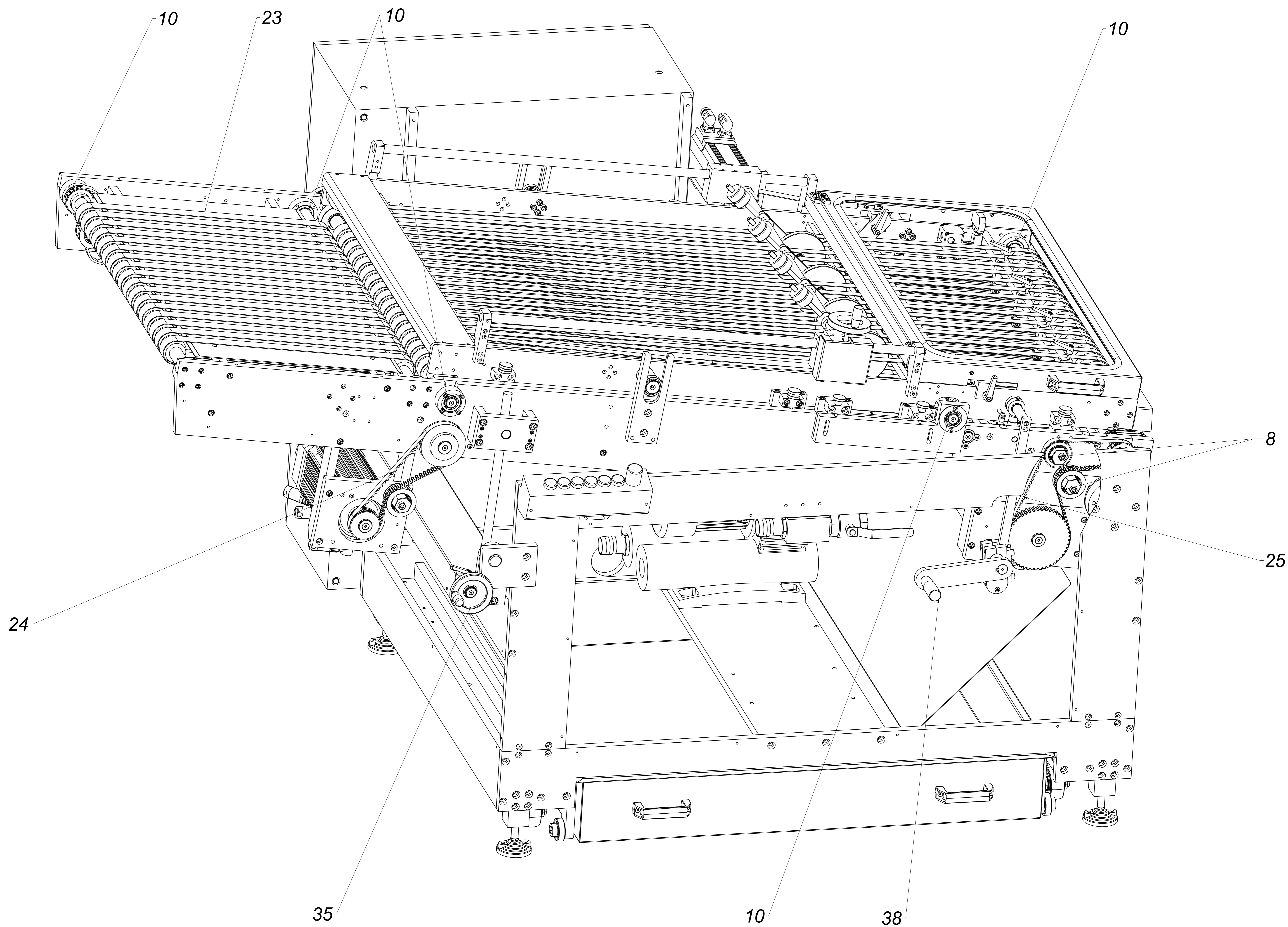

Projekt/Design: 2006.10.27		Mierzyn		Materiał/Material:		Powłoka/Coat:	
Wzrost/Drawn: 2013.11.27				Gabaryt/Dimension:			
				Nazwa/Name:		SSD 770 P-L	
				Złożenie/Assembly:			
				Moduł/Module:			
				Formał/Shape:		No. części/Part num.	
				Sheet:		Supplier:	
				A0		TST-1-0015	
						Masał/Weight:	
						Nie dotyczy	
						Liczba arkuszy/Number of sheets: 7	



BINDER Sp. z o.o.
ul. Bruckowa 6/8 lok. 47
91-341 Łódź
POLAND
tel. +48 42 613 15 95 fax. +48 42 613 15 91

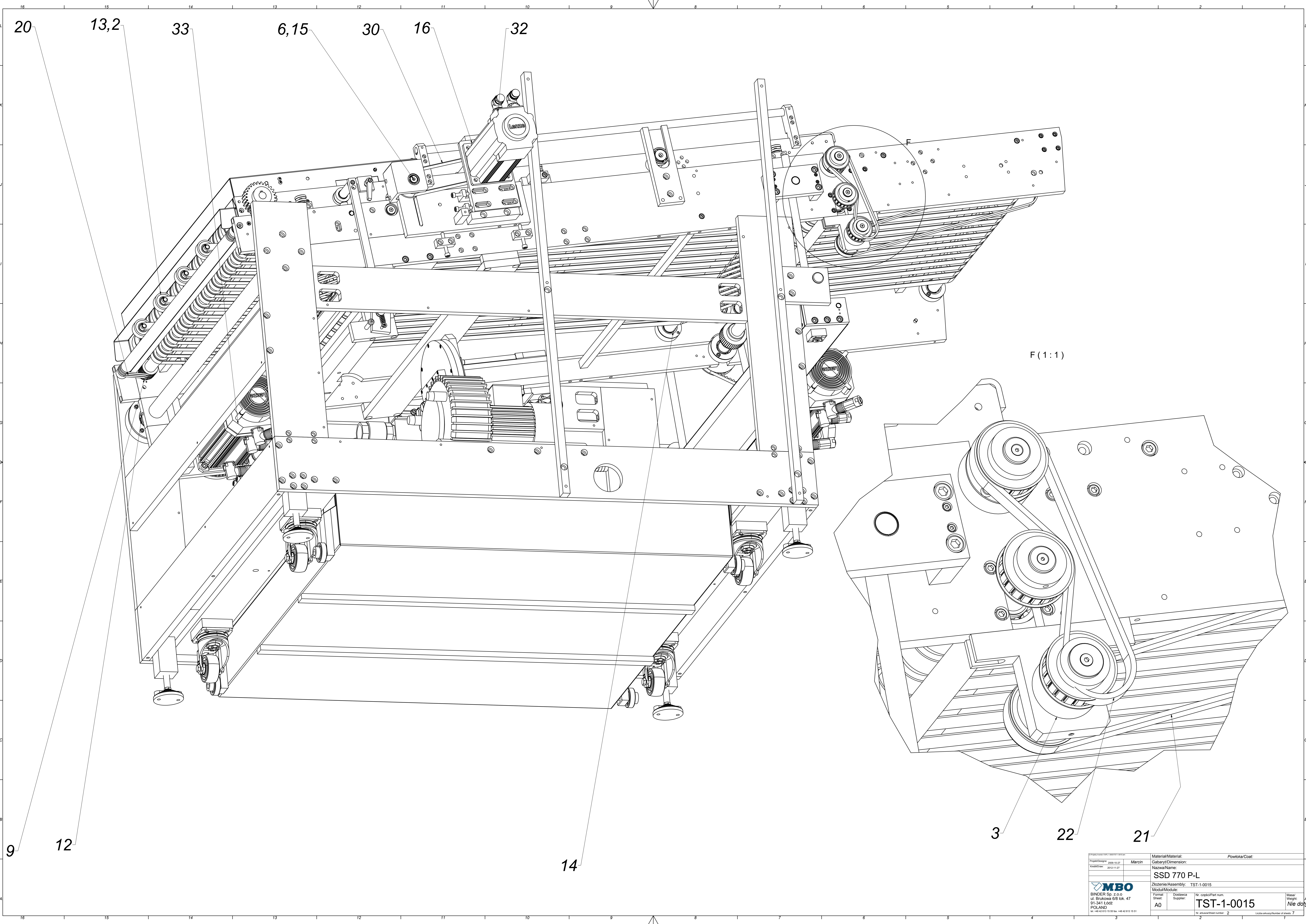

F(1:1)

Projekt/Design: 2009.10.27		Mierzyn		Materiał/Material: Powłoka/Coat:	
Wzrost/Drawn: 2013.11.27				Nazwa/Name:	
				SSD 770 P-L	
				Złożenie/Assembly: TST-1-0015	
				Moduł/Module:	
				Formał/Form: Tłuszcznica	
				Sheet/Supplier:	
				TST-1-0015	
				Masał/Weight:	
				Nie dotyczy	
				Liczba arkuszy/Number of sheets: 7	



BINDER Sp. z o.o.
ul. Bruckowa 6/8 lok. 47
91-341 Łódź
POLAND
tel. +48 42 613 15 95 fax. +48 42 613 15 91

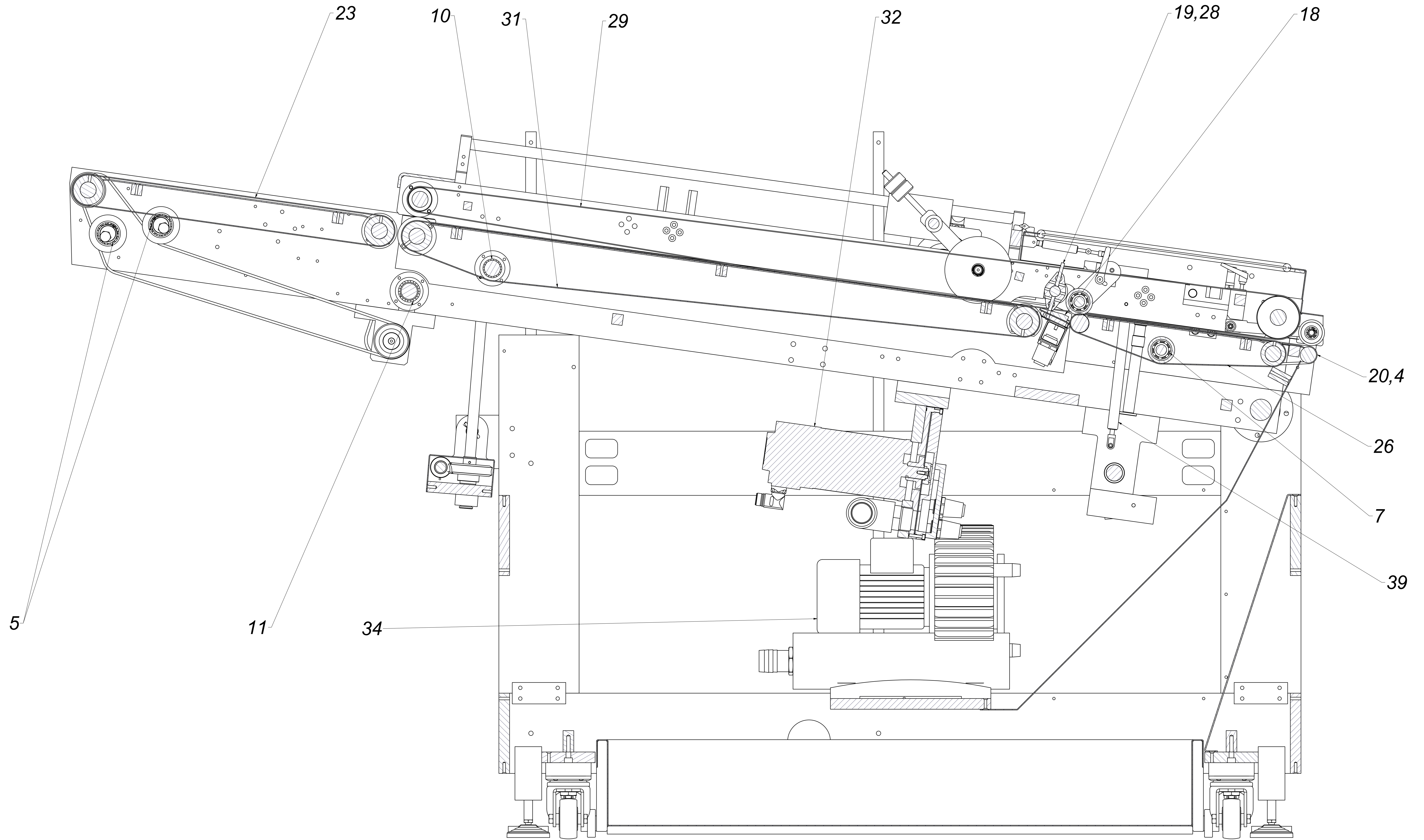

Projekt/Design: 2008.10.27		Mierzyn		Materiał/Material: Powłoka/Coat:	
Kwalifikacja: 2013.11.27				Gabaryt/Dimension:	
				Nazwa/Name:	
				SSD 770 P-L	
				Złożenie/Assembly: TST-1-0015	
				Moduł/Module:	
				Formał/Shape: 1	
				Dostawca/Supplier:	
				TST-1-0015	
				Masał/Weight:	
				Nie dotyczy	
				Liczba arkuszy/Number of sheets: 7	

MBO
 BINDER Sp. z o.o.
 ul. Brzkowa 6/8 lok. 47
 91-341 Łódź
 POLAND
 tel. +48 42 613 15 95 fax. +48 42 613 15 91

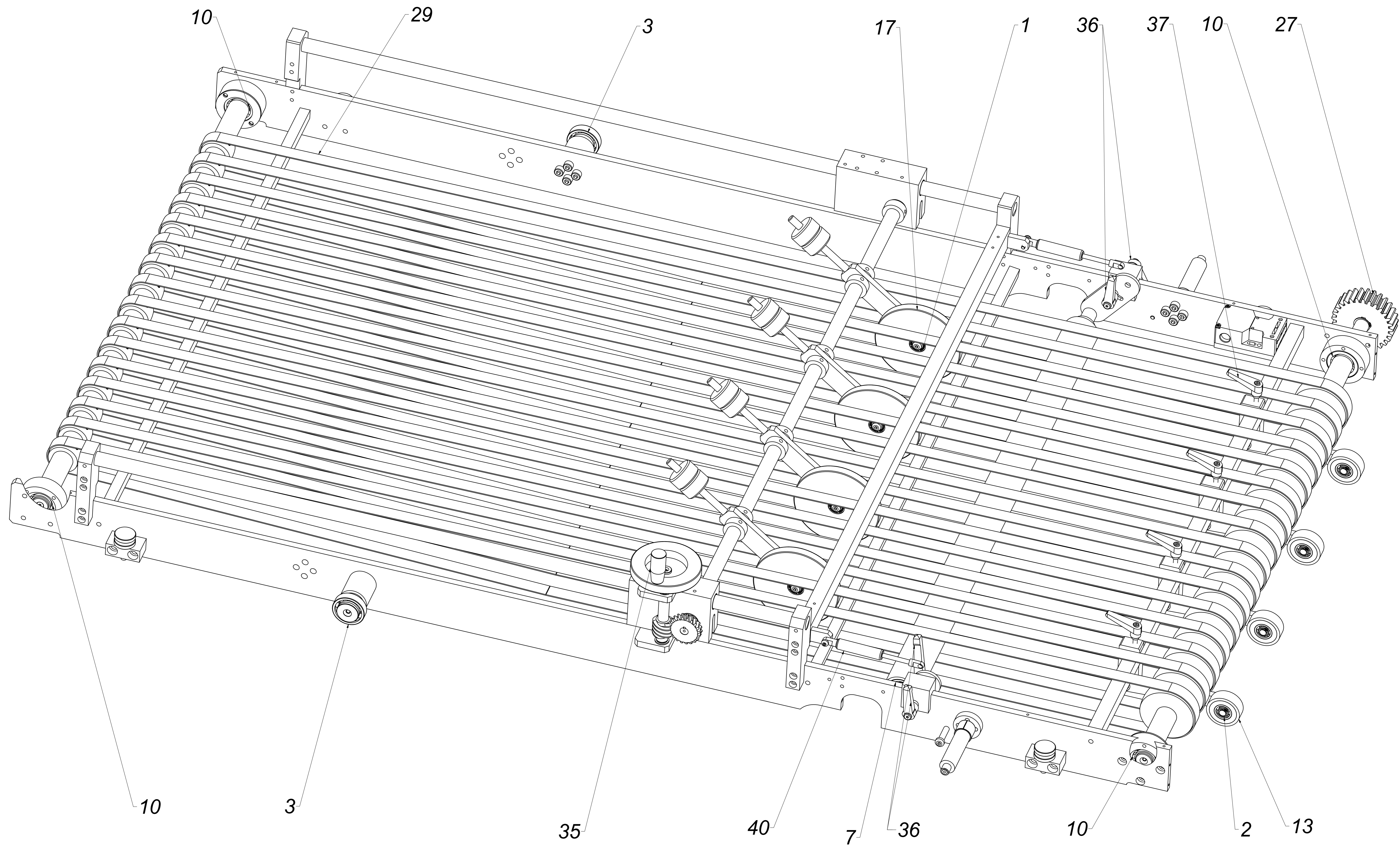

Projekt/Design: 2020.10.30		Krol A.		Materiał/Material: Powłoka/Coat.	
Kwalifikacja: 2013.11.27				Nazwa/Name: Transporter górny	
				Złożenie/Assembly: Moduł/Module: TST-2-0233	
BINDER Sp. z o.o. ul. Bruckowa 6/8 lok. 47 91-341 Łódź POLAND tel. +48 42 617 15 95 fax. +48 42 617 15 91		Forma/Type: Sprężarka Sheet/Supplier:		Nr części/Part num.: TST-2-0233 Masa/Weight: Nie dotyczy Nr arkusza/Sheet number: 4 Liczba arkuszy/Number of sheets: 7	

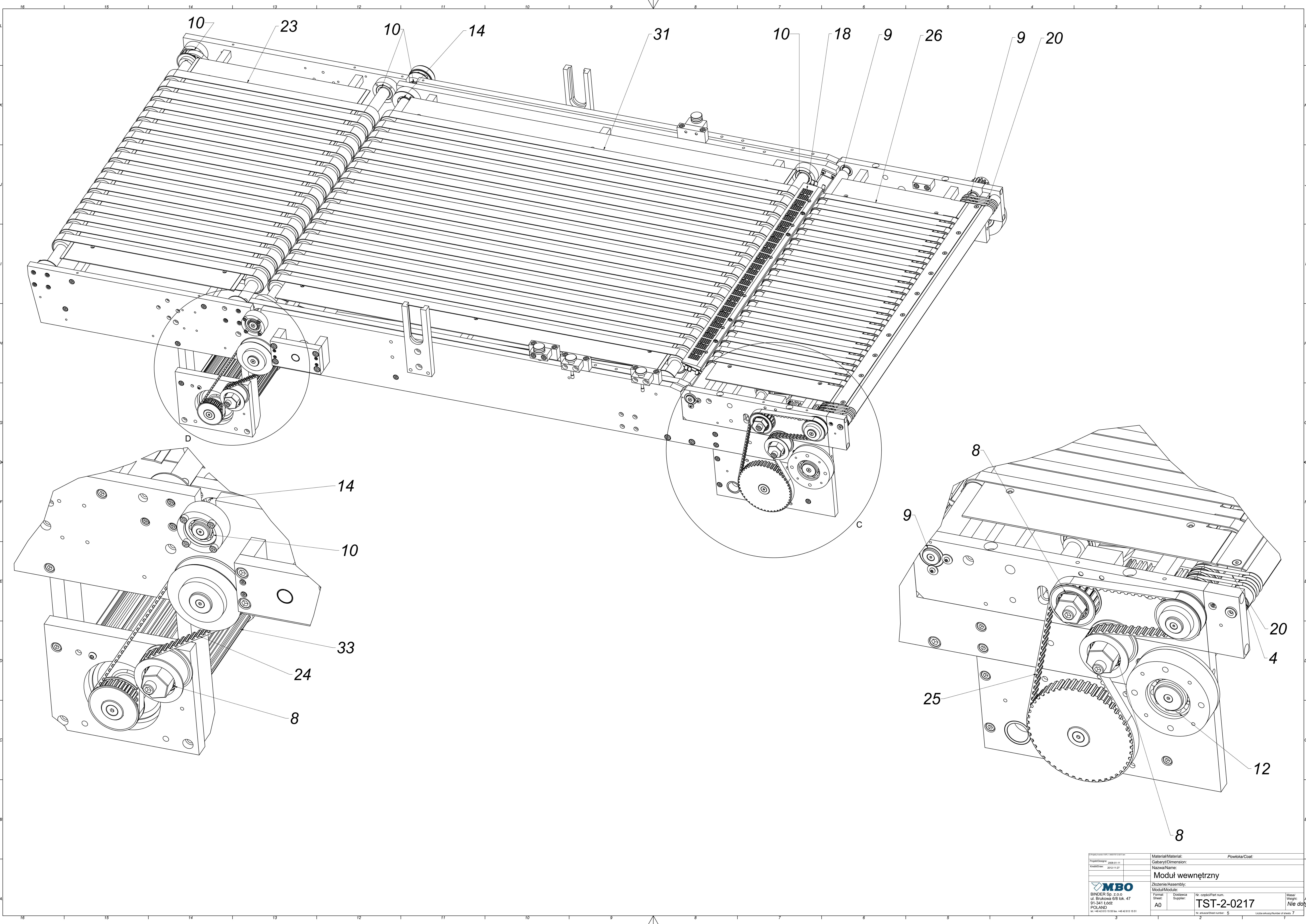

Projekt/Design: 2008.01.11		Materiał/Material: Powłoka/Coat	
Wersja/Ver: 2013.11.27		Nazwa/Name: Moduł wewnętrzny	
Złozenie/Assembly:		Nr części/Part num:	
MBO		TST-2-0217	
BINDER Sp. z o.o. ul. Bruckowa 6/8 lok. 47 91-341 Łódź POLAND tel. +48 42 613 15 95 fax. +48 42 613 15 91		Masał/Weight: Nie dotyczy	
Format: A0		Liczba arkuszy/Number of sheets: 7	

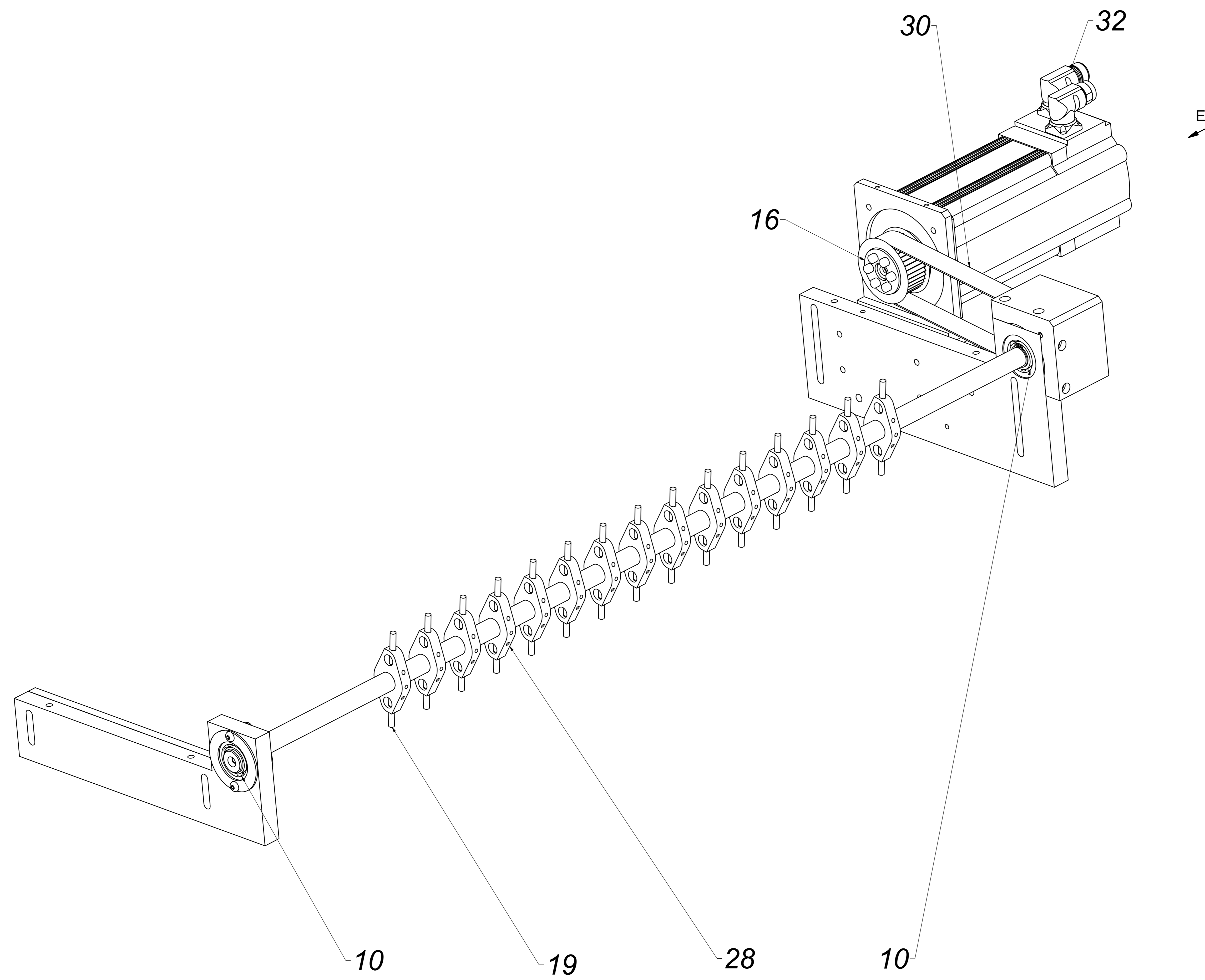

E (1:2)

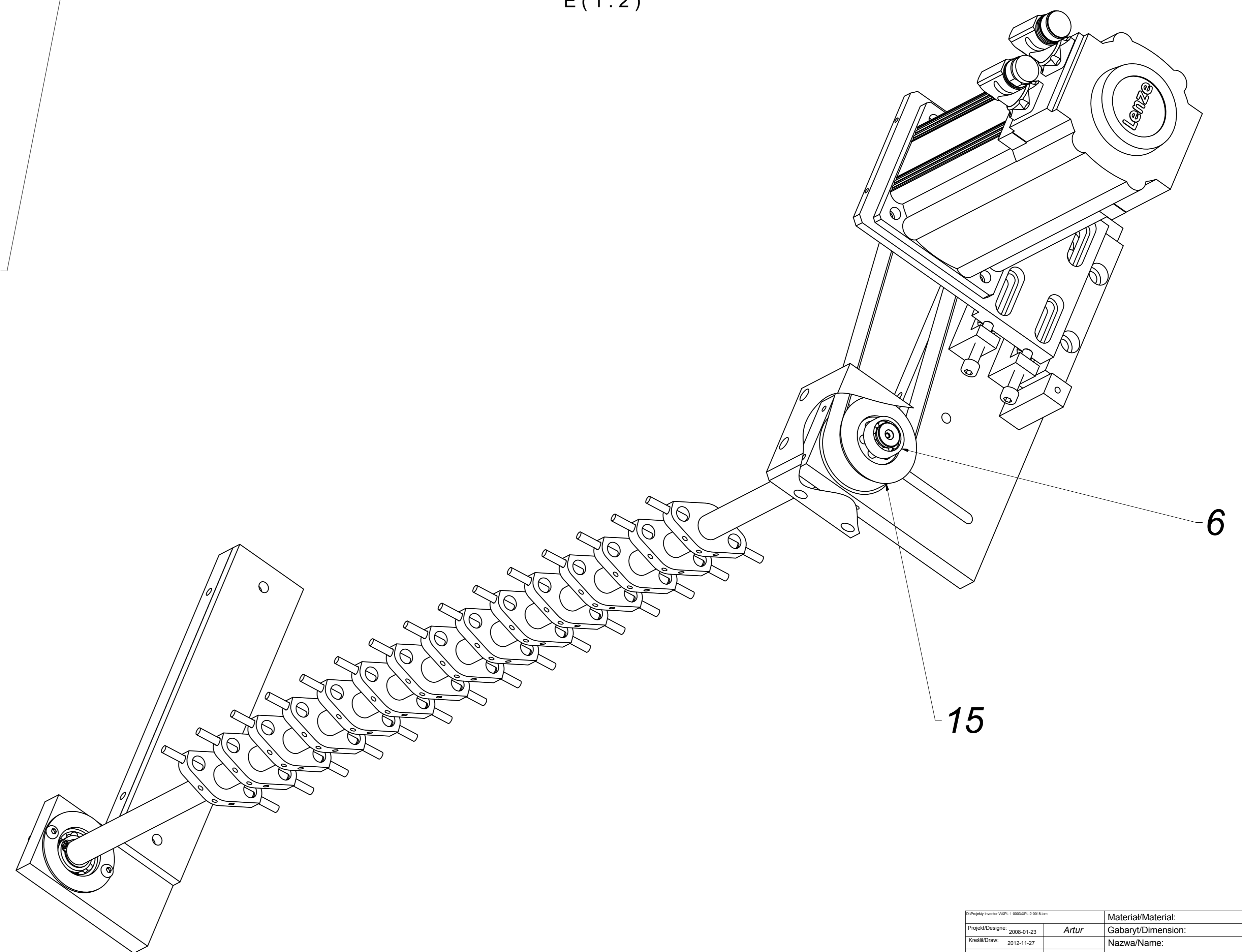

Projekt/Design: 2008.01.23		Autor: Artur		Materiał/Material: Powłoka/Coat.	
Wersja/Ver: 2013.11.27				Gabaryt/Dimension:	
				Nazwa/Name:	
				Zespół docisków	
				Złożenie/Assembly:	
				Moduł/Module:	
				Nr części/Part num:	
				Masał/Weight:	
				Sheet: A0	
				Supplier: XPL-2-0018	
				Nr. skanu/Sheet number: 6	
				Liczba arkuszy/Number of sheets: 7	

MBO
 BINDER Sp. z o.o.
 ul. Brzawska 6/8 lok. 47
 91-341 Łódź
 POLAND
 tel. +48 42 613 15 55 fax. +48 42 613 15 51

Nie dotyczy

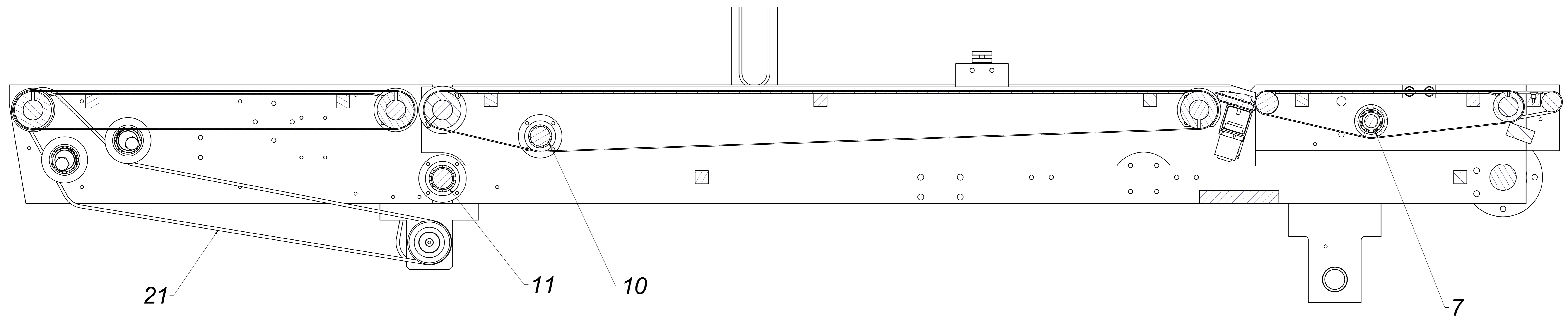

Projekt/Design: 2008.01.11 Wersja/Revizja: 2013.11.27		Materiał/Material: <i>Powłoka/Coat.</i>	
Nazwa/Name:		Gabaryty/Dimension:	
Moduł wewnętrzny		Złożenie/Assembly: TST-1-0015	
Moduł/Module:		Nr części/Part num.:	
Format: A0		Dostawca/Supplier:	
ul. Bruckowa 6/8 lok. 47 91-341 Łódź POLAND tel. +48 42 613 15 95 fax. +48 42 613 15 91		TST-2-0217	
MBO		Liczba arkuszy/Number of sheets: 7	

Masał/Weight: A
Nie dotyczy

POS.	NAZWA	DESIGNATION	BEZEICHNUNG	PART NUMBER
1	Łożyska kulkowe jednorzędowe osłonięte obustronnie	deep groove ball bearing	Rillenkugellager einreihig	DIN 625 SKF - SKF 6000-2Z
2	Łożyska kulkowe jednorzędowe z uszczelką o niskim tarciu obustronnie osłonięte SKF	deep groove ball bearing	Rillenkugellager einreihig, beidseitig geschlossen	DIN 625 SKF - SKF 6005-2RZ
3	Łożyska kulkowe jednorzędowe z uszczelką o niskim tarciu obustronnie osłonięte SKF	deep groove ball bearing	Rillenkugellager einreihig, beidseitig geschlossen	DIN 625 SKF - SKF 6005-2RZ
4	Łożyska kulkowe jednorzędowe z uszczelką o niskim tarciu jednostronnie osłonięte SKF	deep groove ball bearing	Rillenkugellager einreihig, einseitig geschlossen	DIN 625 SKF - SKF 61906-RZ
5	Łożyska kulkowe jednorzędowe osłonięte obustronnie	deep groove ball bearing	Rillenkugellager einreihig	DIN 625 SKF - SKF 6201-2Z
6	Łożysko kulkowe	ball bearing	Kugellager	DIN 625 T1 - 6004 - 20 x 42 x 12
7	Łożysko kulkowe	ball bearing	Kugellager	DIN 625 T1 - 61807 - 35 x 47 x 7
8	Łożysko kulk. wahlwe	self-aligning ball bearing	Pendelkugellager	DIN 630 - 2202 - 15 x 35 x 14
9	Łożysko kulk. wahlwe	self-aligning ball bearing	Pendelkugellager	DIN 630 - 2204 - 20 x 47 x 18
10	Łożysko kulk. wahlwe	self-aligning ball bearing	Pendelkugellager	DIN 630 - 2205 - 25 x 52 x 18
11	Łożysko kulk. Wahlwe	self-aligning ball bearing	Pendelkugellager	DIN 630 - 2207 - 35 x 72 x 23
12	Rolka dociskowa	pressure roller	Andruckrolle	HAR3034
13	Łożyska toczne Łożyska kulkowe wahlwe	self-aligning ball bearing	Pendelkugellager	PN-87/M-86130 - 2205 25 x 52 x 18
14	Sprzęgło COM 14	coupling	Kupplung	Sprzęgło COM 14 615 614 00 Maedler
15	Sprzęgło COM 19	coupling	Kupplung	Sprzęgło COM 19 615 619 00 Maedler
16	Tarcza dociskowa	tension pulley	Spannrolle	TST-3-0350
17	Stolik	table	Tisch	TST-3-0458
18	Pędzelek fi6x30	brush	Pinsel	TST-5-0002
19	Pasek polikordowy fi4	round belt	Rundriemen	TST-5-0012
20	Pasek T10/16 1500	belt	Riemen	TST-5-0027
21	Pasek DT10/16 630	two-ply belt	Doppelriemen	TST-5-0029
22	Pasek MAM-04H	belt	Riemen	TST-5-0044
23	Pasek T10/16-810	belt	Riemen	TST-5-0050
24	Pasek T10/16-1080	belt	Riemen	TST-5-0051
25	Pasek MAM-04H	belt	Riemen	TST-5-0015 4003244
26	Koło zębate z=28 m=3	toothed wheel	Zahnrad	TST6065
27	Zbijak	buffer	Pinselhalter	XPL-3-0073
28	Pasek MAT-02H	belt	Riemen	XPL-5-0003
29	Pasek 5M25HTD 635	belt	Riemen	XPL-5-0004
30	Pasek MAM-04H B=30, L=2350	belt	Riemen	TST-5-0043
31	Silnik	motor	Motor	MCS 12L41-RS0B0
32	Silnik	motor	Motor	MCA 14L35-RS0B0-F10
33	Pompa	pump	Pumpe	SV 8.130/1-01
34	Koło ręczne	hand wheel	Handrad	GN-323-100-K10-D
35	Rękojeść nastawna	adjustable hand lever	verstellbare Klemmhebel	GN300.1-63-M6-SW
36	Rękojeść nastawna	adjustable hand lever	verstellbare Klemmhebel	GN 101-14-M6-20-OR
37	Rękojeść obrotowa	rotatable hand lever	drehbare Klemmhebel	I.601(90+x-M10-INOX
38	Sprężyna gazowa	gas pressure spring	Gasdruckfeder	GS_19_150_A8_A8
39	Sprężyna gazowa	gas pressure spring	Gasdruckfeder	GS-15-40-AA-200

MBO-Gruppe weltweit/ MBO group worldwide/ Le groupe MBO mondial

MBO Deutschland

MBO Maschinenbau Oppenweiler Binder GmbH & Co. KG
Postfach 1169
71567 Oppenweiler
DEUTSCHLAND
Tel.: +49 7191 46-0
Fax: +49 7191 46-34
<http://www.mbo-folder.com>
info@mbo-folder.com

MBO Portugal

MBO Binder-Maquinas Graficas, S.A.
Rua Joaquim Alves da Silva 240
4456-473 Perafita
PORTUGAL
Tel.: +351 22 99822-00
Fax: +351 22 99822-01
<http://www.mbo-folder.com>
info@mbo-folder.com

MBO Amerika

MBO Binder & Co. of America
400 Highland Drive
Westampton, NJ 08060
USA
Tel.: +1 609 267 2900
Fax: +1 609 267 1477
<http://www.mboamerica.com>
info@mboamerica.com

MBO Frankreich

MBO France SAS
Z. A. Burospace N° 3
Route de Gisy B.P. 33
91571 Bievres Cedex
FRANCE
Tel.: +33 1 6935 5090
Fax: +33 1 6935 5099
<http://www.mbo-folder.com>
info@mbofrance.fr

MBO China

MBO Binder Graphic Systems (Beijing) Co. Ltd.
No.3 Building, Xing Sheng Industry Park,
No.7 Tong Ji Zhong Lu, BDA,
Beijing 100176
P.R. CHINA
Tel.: +86 10 6786 2741
Fax: +86 10 6786 2743
<http://www.mbo-folder.com.cn>

Herzog & Heymann

Herzog & Heymann GmbH & Co. KG
Postfach 110355
33663 Bielefeld
DEUTSCHLAND
Tel.: +49 5205 7509-0
Fax: +49 5205 7509-20
<http://www.herzog-heyman.com>
info@herzog-heyman.com